

Aquasurf® Solid Surface Shower Receptors

Round, Angular

✓	MODEL NUMBER	SIZE
	AS-S36NEO	36" x 36" NEO-ANGLE
	AS-S42NEO	42" x 42" NEO-ANGLE
	AS-S36RND	36" x 36" ROUND FRONT

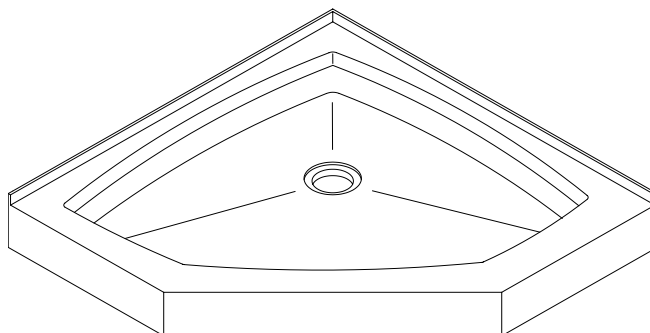

NEO Angle Shown

Recommended Specifications _____

Solid Surface Shower Receptor shall be Aquasurf® Solid Surface Products monolithic cast model #AS-S_____ (select from table).

Aquasurf® Solid Surface Products Shower Receptors are designed for single and multiple applications. The Shower Receptor shall be a monolithic cast component of Aquasurf® Solid Surface Products polymer materials, composed of fully densified aluminum trihydrate mineral fillers, homogeneously blended in a engineered, UV stabilized, acrylic modified polyester resin.

Shower Receptor shall have integrally molded support bracing on bottom, positive sloped non-slip textured interior floor, and integral perimeter flange. Aquasurf® Solid Surface Products Shower Receptors shall incorporate, integral threshold, and curb, and 3 1/2" standard drain opening, (for 2" No-Hub connection).

Shower Receptor shall be available in Solid Color or Granite Pattern (indicate color selection). Solid Surface Shower Receptor shall comply with ANSI Z124.2.

Vandal Resistance:

Aquasurf® Solid Surface Products Shower Receptors offer high impact, chip, scratch, and burn resistance. Topical surface damages can easily be repaired with minor abrasive applications (3M #7448 Scotch-Brite®). The viral, bacteriological, chemical, mildew, and mold resistance provides a sanitary, easily cleaned, durable, low maintenance component.

Optional Features:

Aquasurf® Solid Surface Products wall panel kits with overlay battens, coved corners; soap/shampoo assemblies provide all components required to complete shower area enclosure (refer to selection sheet for unit designation).

Visit our website at <http://www.willoughby-ind.com>

2210 West Morris Street • P.O. Box 21217 • Indianapolis, IN 46221

(317) 638-2381 • Fax: (317) 638-6110 • (800) 428-4065

MODEL NUMBER AND OPTIONS:

1.) Receptacle Type:

- AS-S36NEO 36x36 Neo Angle
- AS-S42NEO 42x42 Neo Angle
- AS-S36RND 36x36 Round Front

2.) Wall Kits (3/8" Panels):

- ASK-S36NEO (2)-36x72 Panels
- ASK-S42NEO (2)-42x72 Panels
- ASK-SRND (2)-36x72 Panels

3.) Commercial Wall Kits (1/4" Panels):

- ASK-S36NEOS (2)-36x84 Panels
(2)-6x84 Jamb Panels
- ASK-S42NEOS (2)-42x84 Panels
(2)-6x84 Jamb Panels
- ASK-S36RND (2)-36x84 Panels
(2)-6x84 Jamb Panels

4.) Accessories:

- AS-ISCR Inside Corner Overlay Trim
- AS-IS-CV8 Inside Corner Cove Overlay
- ASK-UP84 Upgrade Kit to 84"
- AS-SSH Soap/Shampoo Holder

Drawing Approved For Manufacturing By: _____ Date: _____ Company: _____
 Wall Thickness: _____ Wall Type: _____

VERIFY ALL DIMENSIONS PRIOR TO ROUGH-IN

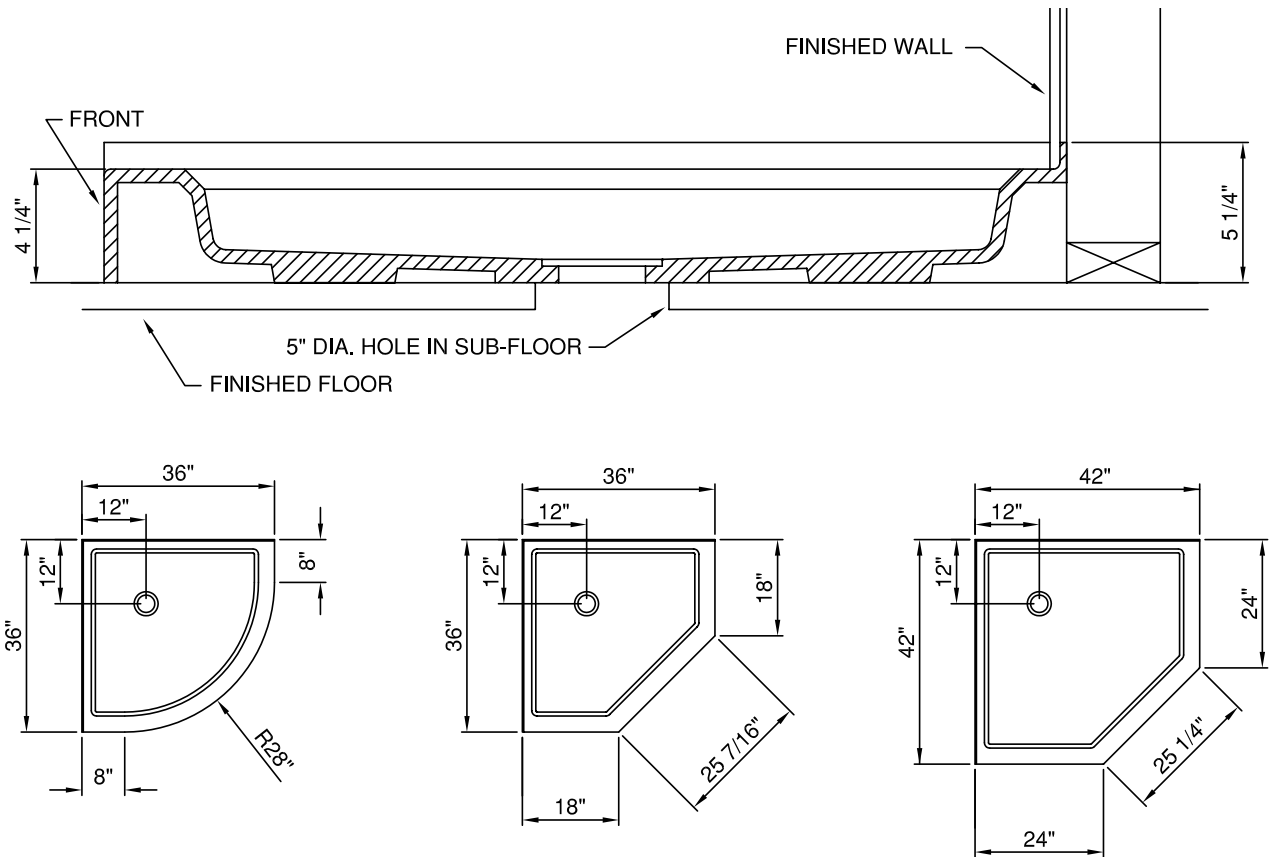

Willoughby Industries, Inc.