

BETF-1490-FM-FA-12" Bariatric Toilet Floor Outlet Front Mounted 12" Rough-In

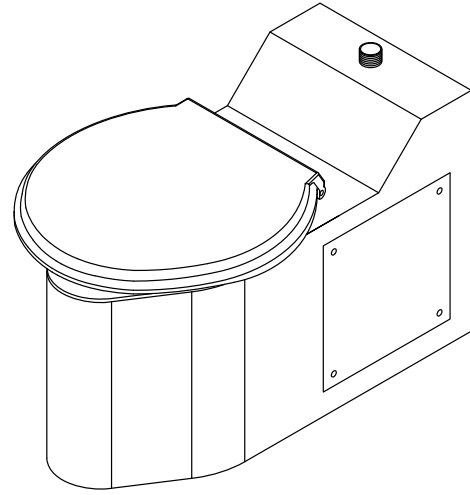

(Some options may be shown)

✓	MODEL NUMBER	INLET LOCATION
	BETF-1490-FM-FA-12"-BS	BACK
	BETF-1490-FM-FA-12"-TS	TOP*

* Top inlet shown in drawing



Recommended Specifications

Toilet shall be Willoughby Model No. **BETF-1490-FM-FA-12"-__** (select from table above).

Fixture shall be fabricated from heavy gauge, type 304 stainless steel. The construction shall be all-welded. Fixture exterior shall have a gloss white powder coat enamel finish. Toilet bowl interior shall have a sanitary bead blast stainless steel finish.

Standard toilet shall include: elongated toilet bowl with integral contoured seat, integral crevice-free self-draining flushing rim with positive afterfill and fully enclosed 2 1/2" O.D. trap which shall maintain a minimum 3 1/2" seal and pass a 2 1/8" ball. Toilet shall be siphon jet type which requires 25 psi minimum flushing pressure. Hinged toilet seat shall have open front with cover and be rated for 1200 lbs. weight capacity. Toilet seat hinges shall be stainless

steel, seat and cover shall be white in color.

Fixture (less hinged seat) shall withstand loadings up to 2,000 lbs. with no measurable deflection and loadings up to 5,000 lbs. with no permanent damage.

Anchoring shall be from the front thru two (2) 12"x12" removable access panels. The fixture is provided with four (4) 3/4" wall mounting holes and one (1) floor mounted Z-Clip mounting bracket. Wall and floor anchoring hardware by others.

MODEL NUMBER AND OPTIONS:

1.) Toilet Waste Location:

BETF Floor

2.) Base Model Number:

1490

3.) Fixture Mounting:

FM Floor Mounted

4.) Front Access:

FA Front Access

5.) Waste Rough-In:

12" Rough-In

7.) Options:

- BL Bed Pan Lugs
- SLL Seat Less Lid (For Use W/Bed Pan Washer)
- FV Flush Valve
- FVC Flush Valve Cover (Top Spud)
- FVT Flush Valve Connection
- AP Flush Valve Access Panel
- LF Low-Flow, 1.6 Gallon Flush (standard)
- SF Standard-Flow, 3.5 Gallon Flush
- MT Metal Template
- RTH1 Wall Mounted Recessed Tissue Holder
- RTH2 Wall Mounted Recessed Tissue Holder (Front Access)
- Other: _____
- Other: _____

6.) Inlet Location:

BS Back Spud

TS Top Spud

Drawing Approved For Manufacturing By: _____ Date: _____ Company: _____

Wall Thickness: _____ Wall Type: _____

VERIFY ALL DIMENSIONS PRIOR TO ROUGH-IN

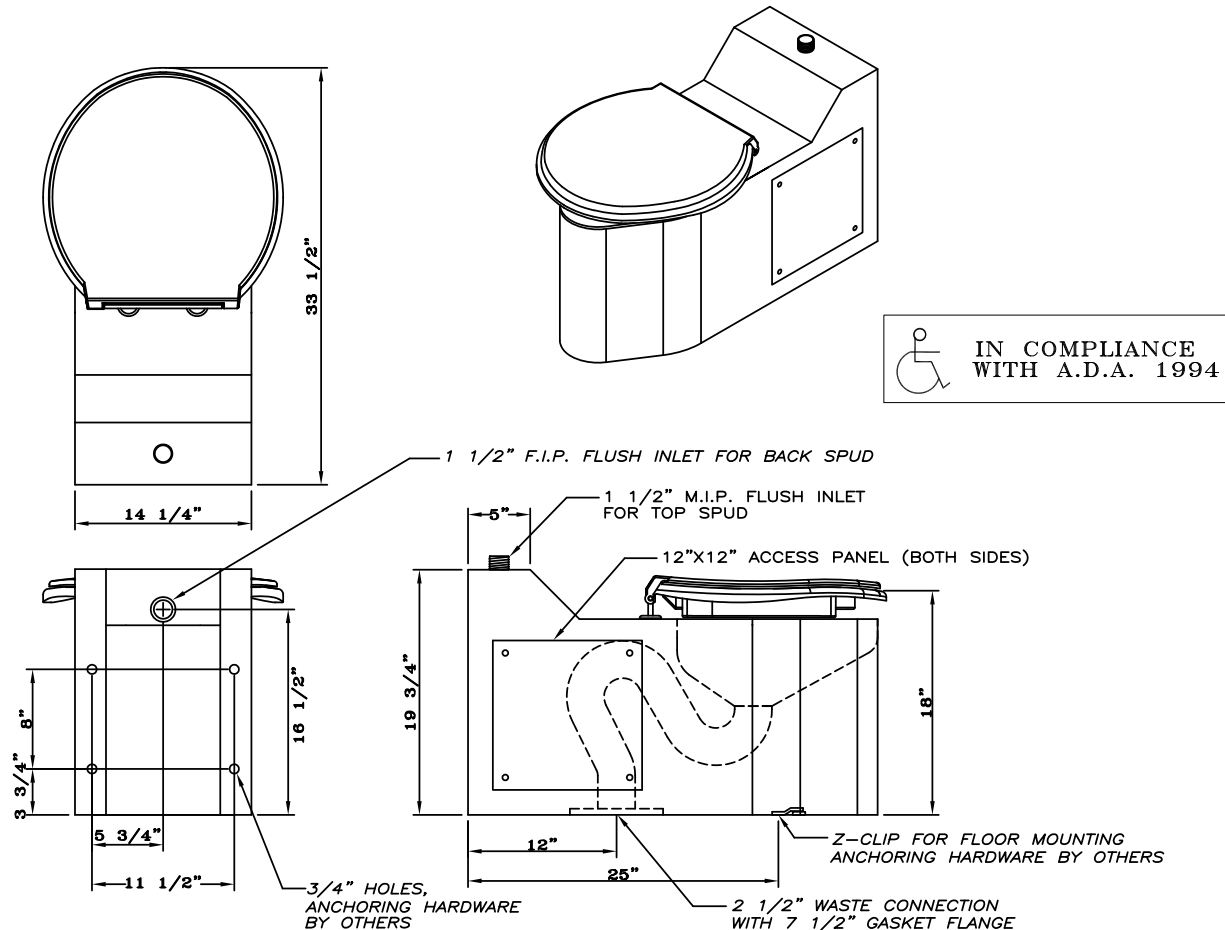

IN COMPLIANCE WITH A.D.A. 1994

Willoughby Industries, Inc.