

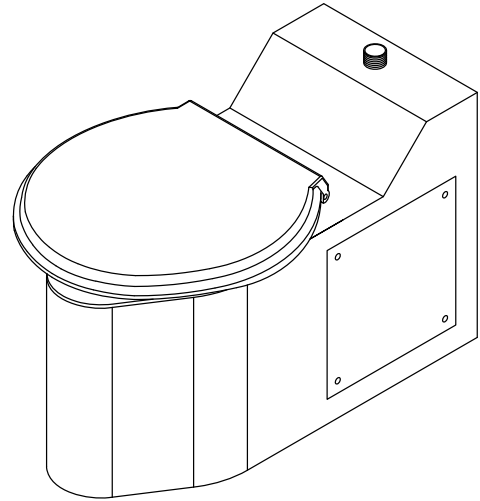

BETW-1490-FM-FA Bariatric Toilet Blowout Series Wall Outlet

✓	MODEL NUMBER	INLET LOCATION
	BETW-1490-FM-FA-BS	BACK
	BETW-1490-FM-FA-TS	TOP*

* Top inlet shown in drawing



Recommended Specifications

Toilet shall be Willoughby Model No. **BETW-1490-FM-FA-**____ (select from table above).

Fixture shall be fabricated from heavy gauge, type 304 stainless steel. The construction shall be all-welded. Fixture exterior shall have a gloss white powder coat enamel finish. Toilet bowl interior shall have a sanitary bead blast stainless steel finish.

Standard toilet shall include: elongated toilet bowl with integral contoured seat, integral crevice-free self-draining flushing rim with positive afterfill and fully enclosed 2 1/2" O.D. trap which shall maintain a minimum 3 1/2" seal and pass a 2 1/8" ball. Toilet shall be blow-out type which requires 25 psi minimum flushing pressure. Hinged toilet seat shall have open front with cover and be rated for 1200 lbs. weight capacity. Toilet seat hinges shall be stainless steel, seat and cover shall be white in color.

Fixture (less hinged seat) shall withstand loadings up to 2,000 lbs. with no measurable deflection and loadings up to 5,000 lbs. with no permanent damage.

Anchoring shall be from the front thru two (2) 12"x12" removable access panels. The fixture is provided with three (3) 7/8" wall carrier mounting holes and one (1) floor mounted Z-Clip mounting bracket. Wall and floor anchoring hardware by others. The fixture is floor mounted and is designed to mate with a three (3) bolt blow-out carrier.

On back to back fixture installations, do not use standard cross type waste fittings: cross flow may result due to blowout jet action. Use sanitary or offset type waste fittings.

Made In The **U.S.A.**



Visit our website at <http://www.willoughby-ind.com>

2210 West Morris Street • P.O. Box 21217 • Indianapolis, IN 46221

(317) 638-2381 • Fax: (317) 638-6110 • (800) 428-4065

MODEL NUMBER AND OPTIONS:

1.) Toilet Waste Location:

BETW Wall

2.) Base Model Number:

1490

3.) Fixture Mounting:

FM Floor Mounted

4.) Front Access:

FA Front Access

5.) Inlet Location:

BS Back Spud

TS Top Spud

6.) Options:

BL Bed Pan Lugs

SLL Seat Less Lid (For Use W/Bed Pan Washer)

FV Flush Valve

FVC Flush Valve Cover (Top Spud)

FVT Flush Valve Connection

AP Flush Valve Access Panel

LF Low-Flow, 1.6 Gallon Flush (standard)

SF Standard-Flow, 3.5 Gallon Flush

MT Metal Template

RTH1 Wall Mounted Recessed Tissue Holder

RTH2 Wall Mounted Recessed Tissue Holder (Front Access)

Other: _____

Other: _____

Drawing Approved For Manufacturing By: _____ Date: _____ Company: _____

Wall Thickness: _____ Wall Type: _____

VERIFY ALL DIMENSIONS PRIOR TO ROUGH-IN

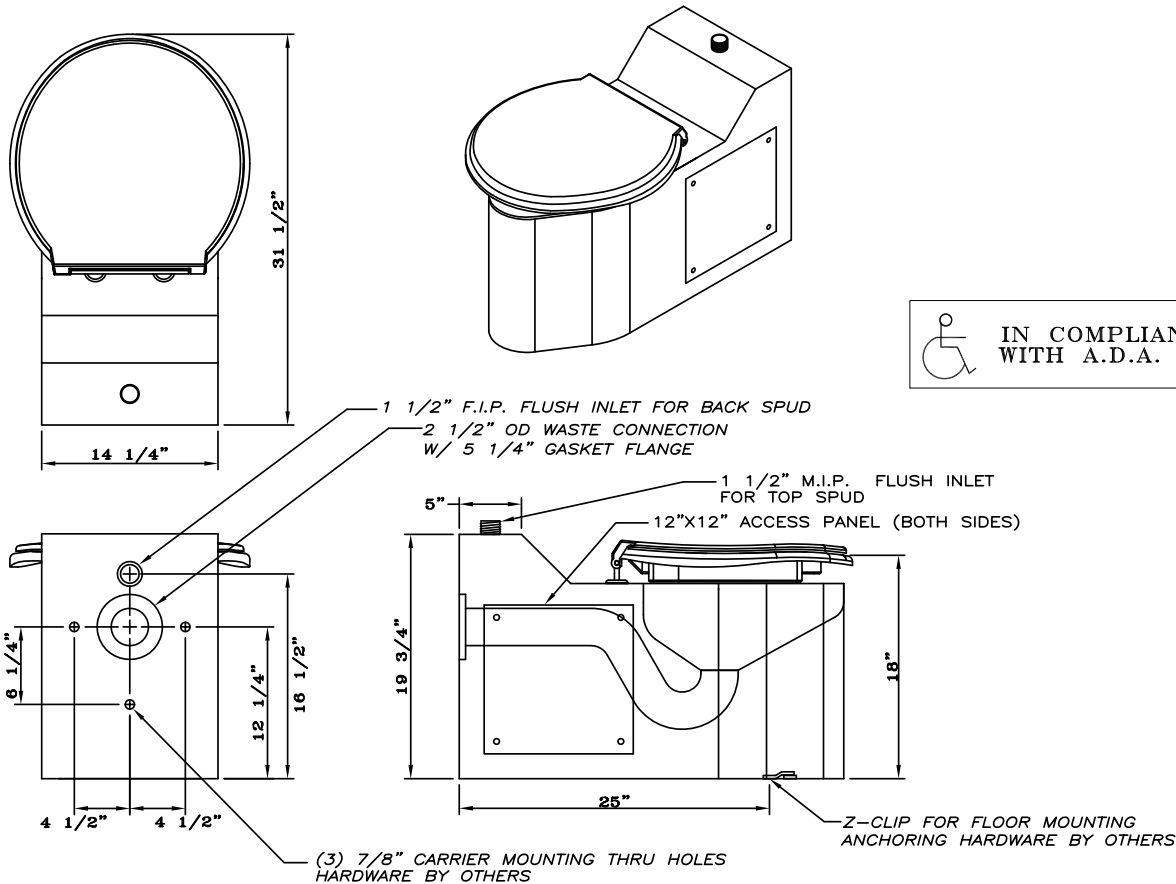

Willoughby Industries, Inc.

Made In The U.S.A.

