

CWSMSH-Series Hinged Single Station Surface Mounted Wall Shower

✓	MODEL NUMBER	VALVE TYPE
	CWSMSH-PM1	SINGLE TEMP PNEU. METERING
	CWSMSH-PM2	DUAL TEMP PNEU. METERING
	CWSMSH-EL1	SINGLE TEMP ELECTRONIC
	CWSMSH-EL2	DUAL TEMP ELECTRONIC
	CWSMSH-PB	PRESSURE BALANCING
	CWSMSH-TSV	THERMOSTATIC
	CWSMSH-H	SINGLE TEMP COMPRESSION
	CWSMSH-HC	DUAL TEMP COMPRESSION
	CWSMSH-NV	NO VALVE

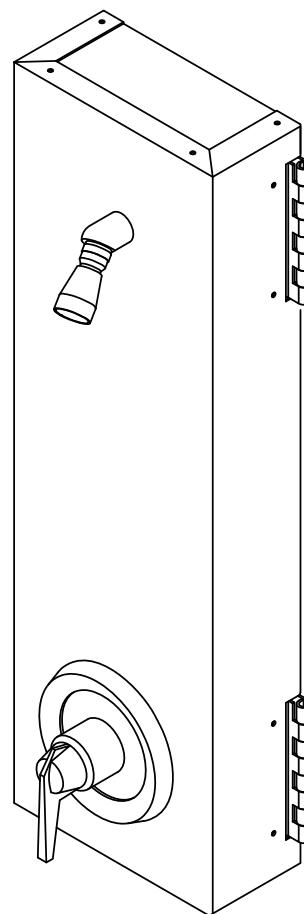

(Some options may be shown)

Recommended Specifications _____

Surface mounted hinged single station shower shall be Willoughby Model No. **CWSMSH-**____ (select valve from table above).

Hinged shower panel shall be fabricated from 18 gauge, type 304 stainless steel with exposed stainless surfaces polished to a #4 satin finish. Top and bottom panels are rivited on to shower panel.

Standard equipment shall include: shower valve _____ (as selected from table above), UBJ universal ball joint showerhead.

Anchoring shall be by (2) 1" open hinges with 5/16" mounting holes and (2) 5/16" mounting tabs, with anchoring hardware by others. Unit requires no chase area for installation and maintenance.

Made In The U.S.A.



Visit our website at <http://www.willoughby-ind.com>

2210 West Morris Street • P.O. Box 21217 • Indianapolis, IN 46221

(317) 638-2381 • Fax: (317) 638-6110 • (800) 428-4065

MODEL NUMBER AND OPTIONS:

1.) Shower Head Height

(Not Part of Model Number):

- 6'-0"
- 5'-6"
- 5'-0"
- 4'-0"
- Other _____"

4.) Shower Head Options:

- APS Adjustable Penal Showerhead
- NPS Non-Adjustable Penal Showerhead
- UBJ Universal Ball Joint Shower Head (Standard)
- UDBJ Up Down Ball Joint Shower Head
- LBJ Lockable Ball Joint Shower Head

2.) Base Model Number:

- CWSMSH Hinged Single Station
Surface Mounted Shower

.) Options:

- GB Grab Bar (Specify Dimensions)
- GX Individual Checkstops
- RSD-2 Recessed Soap Dish,
(in wall, front mounted)
- WA-1836 Surface Mounted Soap Dish,
(on wall, front mounted)
- Other: _____
- Other: _____

3.) Valve Selection:

- PM1 Single Temp. Pneu. Metering
- PM2 Dual Temp. Pneu. Metering
- EL1 Single Temp. Electronic
- EL2 Dual Temp. Electronic
- PB Pressure Balancing
- TSV Thermostatic Mixing Valve
- H Single Temp. Compression
- HC Dual Temp. Compression
- NV No Valve

Drawing Approved For Manufacturing By: _____ Date: _____ Company: _____
 Wall Thickness: _____ Wall Type: _____

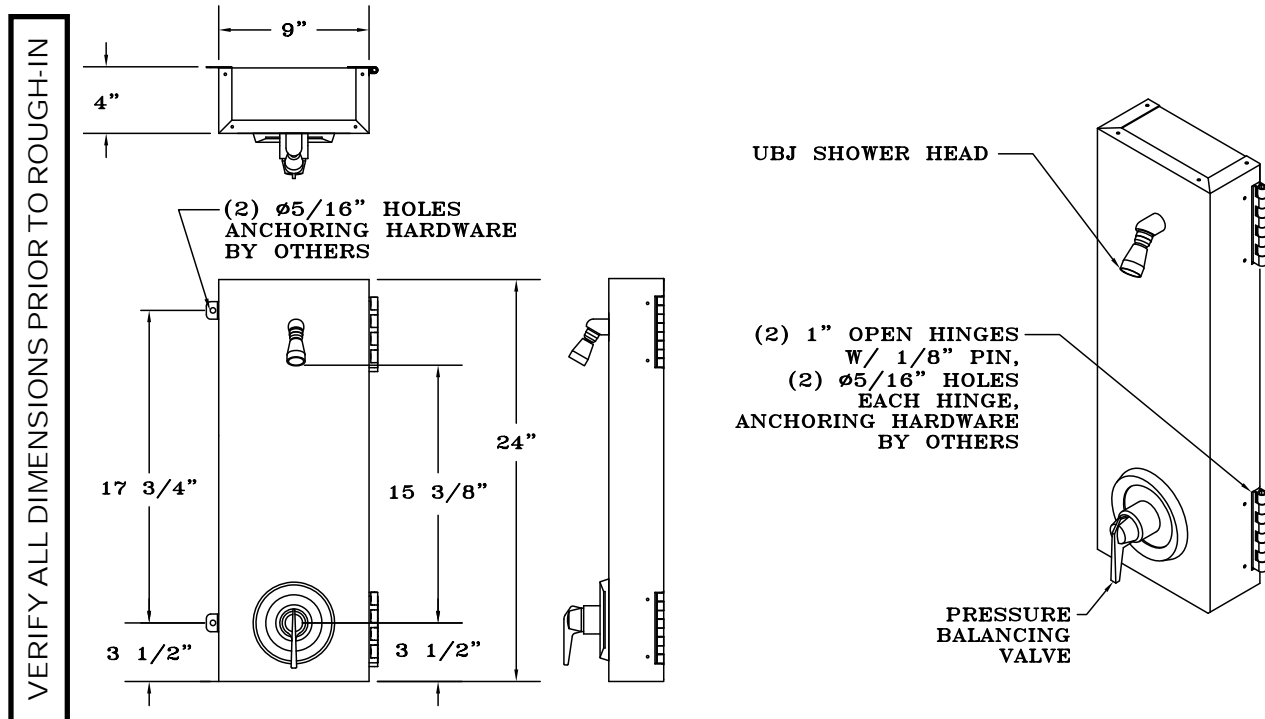

To specify fixture and accessories, use the Model Number and Options Guide.
 Example: To specify a surface mounted hinged single station shower with single temp. pneumatic metering valve, adjustable penal showerhead and recessed mounted soap dish. Use the following Willoughby Model Number: CWSMSH-PM1-UBJ
 Willoughby Model Number: CWSMSH-PM1-UBJ

Willoughby Industries, Inc.

Made In The U.S.A.

