

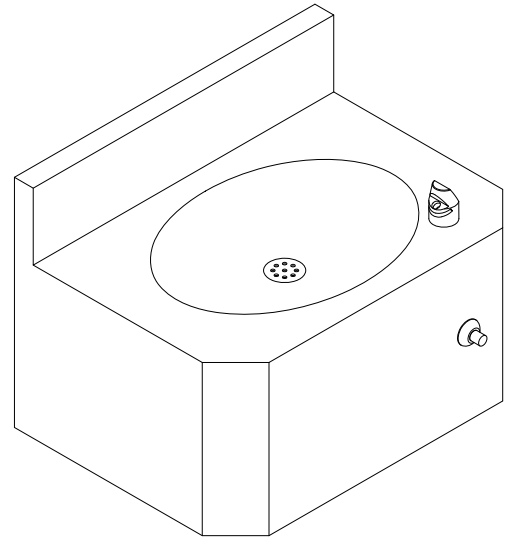

## DF-1013-96

### Drinking Fountain



### Recommended Specifications

---

Drinking fountain shall be Willoughby Model No. **DF-1013-96**.

Fixture shall be fabricated from 14 gauge, type 304 stainless steel. The construction shall be all-welded, with exposed stainless surfaces polished to a #4 satin finish.

Standard equipment shall include: oval basin, 13" x 9 1/2" x 1 1/2" deep, stainless steel bubbler, fast drain with air vent, elbow waste (1 1/2" FIP) and factory provided single tem-

perature pneumatic self-closing valve. Valve is chase mounted by contractor.

Cabinet interior shall be sound deadened with fire-resistant material.

Anchoring shall be by standard 4-point system: 1/2" threaded rods, nuts and washers shall be furnished for walls up to 8" thick. Unit shall require chase area for installation and maintenance.

*Made In The U.S.A.*



*Visit our website at <http://www.willoughby-ind.com>*

2210 West Morris Street • P.O. Box 21217 • Indianapolis, IN 46221

(317) 638-2381 • Fax: (317) 638-6110 • (800) 428-4065

# MODEL NUMBER AND OPTIONS:

**1.) Drinking Fountain Type:**

DF

**2.) Base Model Number:**

1013-96 18" Drinking Fountain

**3.) Bubbler or Spout Selection:**

DB Drinking Fountain Bubbler

**4.) Valve Selection:**

PS1 Single Temp. Pneumatic Self-Closing

SC1 Single Temp. Mechanical Self-Closing

**5.) Drinking Fountain Waste:**

EB Elbow Waste (Standard)

PT Integral P-Trap

LWE Lavatory Waste Extension

LW1 Thru-Wall Extension, P-Trap & Clean-out

LW2 Thru-Wall Extension & Clean-out

**6.) Options:**

MT Metal Template

WS Wall Sleeve

Other: \_\_\_\_\_

Other: \_\_\_\_\_

Drawing Approved For Manufacturing By: \_\_\_\_\_ Date: \_\_\_\_\_ Company: \_\_\_\_\_

Wall Thickness: \_\_\_\_\_ Wall Type: \_\_\_\_\_

VERIFY ALL DIMENSIONS PRIOR TO ROUGH-IN

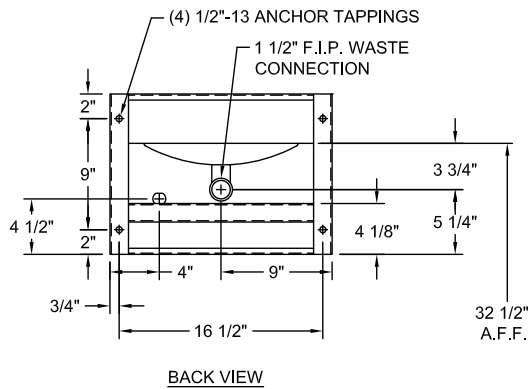
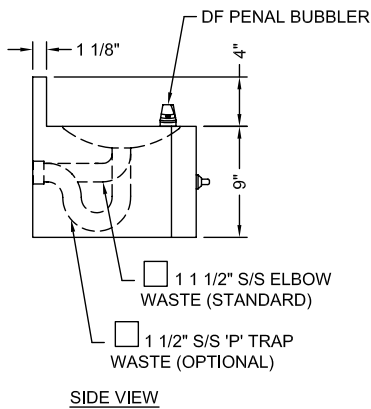
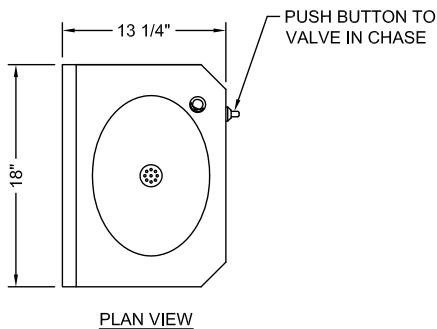

To specify fixture and accessories, use the Model Number and Options Guide.

Example: To specify an DF-1013-96 drinking fountain with drinking fountain bubbler, single temp. pneumatic self-closing valve, and wall sleeve. Use the following Willoughby Model Number:

Willoughby Model Number: DF-1013-96-DB-PS1-WS

*Made In The U.S.A.*



## Willoughby Industries, Inc.