

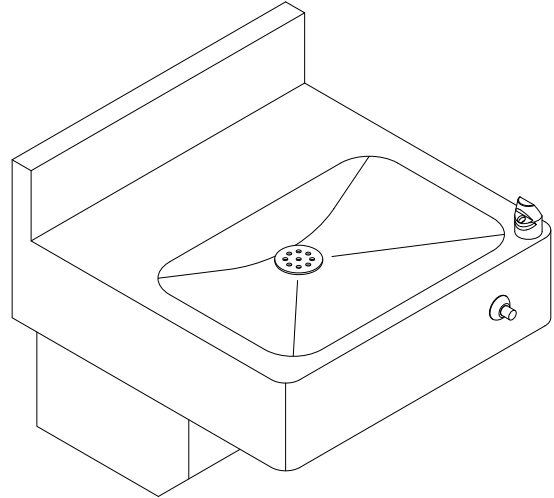

## DF-1015-96-HC-FA Handicap Front Access Drinking Fountain



### Recommended Specifications

---

Handicap front access drinking fountain shall be Willoughby Model No. **DF-1015-96-HC-FA**.

Fixture shall be fabricated from 14 gauge, type 304 stainless steel. The construction shall be all-welded, with exposed stainless surfaces polished to a #4 satin finish.

Standard equipment shall include: rectangular shaped basin, 14 1/2" x 10" x 1" deep, stainless steel bubbler, fast

drain with air vent, 1 1/2" slip joint, cast brass union p-trap, factory mounted single temperature pneumatic self-closing valve, and removable bottom panel attached with vandal resistant screws.

Anchoring shall be from the front with z-clip and anchoring holes provided. Anchoring hardware by others. Unit requires no chase area for installation and maintenance.

*Made In The U.S.A.*



*Visit our website at <http://www.willoughby-ind.com>*

2210 West Morris Street • P.O. Box 21217 • Indianapolis, IN 46221

(317) 638-2381 • Fax: (317) 638-6110 • (800) 428-4065

# MODEL NUMBER AND OPTIONS:

**1.) Drinking Fountain Type:**

DF

**2.) Base Model Number:**

1015-96-HC 18" Handicap Drinking Fountain

**3.) Front Access:**

FA Front Access

**4.) Bubbler or Spout Selection:**

DB Drinking Fountain Bubbler

**5.) Valve Selection:**

PS1 Single Temp. Pneu. Self-Closing

**6.) Drinking Fountain Waste:**

MT Metal Template

Other: \_\_\_\_\_

Other: \_\_\_\_\_

Drawing Approved For Manufacturing By: \_\_\_\_\_ Date: \_\_\_\_\_ Company: \_\_\_\_\_

Wall Thickness: \_\_\_\_\_ Wall Type: \_\_\_\_\_

VERIFY ALL DIMENSIONS PRIOR TO ROUGH-IN

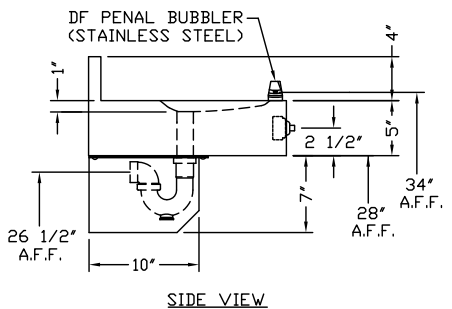
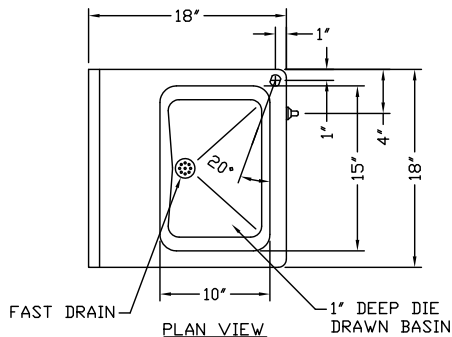

IN COMPLIANCE WITH A.D.A. 1990

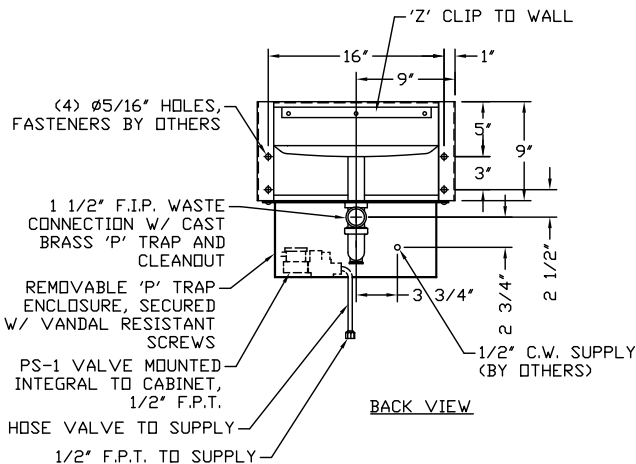

To specify fixture and accessories, use the Model Number and Options Guide.  
Example: To specify a DF-1015-96-HC-FA handicap front access drinking fountain with drinking fountain bubbler, single temp, pneumatic self-closing valve. Use the following Willoughby Model Number:  
Willoughby Model Number: DF-1015-96-HC-FA-DB-PS1



Made In The U.S.A.

## Willoughby Industries, Inc.