

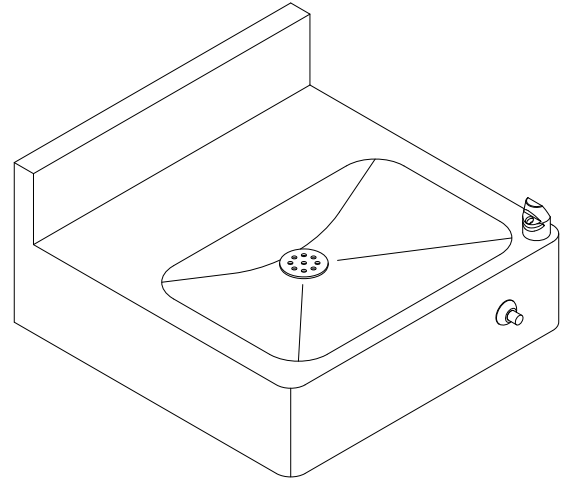

## DF-1015-96-HC Handicap Drinking Fountain



### Recommended Specifications

---

Handicap drinking fountain shall be Willoughby Model No. **DF-1015-96-HC.**

Fixture shall be fabricated from 14 gauge, type 304 stainless steel. The construction shall be all-welded, with exposed stainless surfaces polished to a #4 satin finish.

Standard equipment shall include: rectangular shaped basin, 14 1/2" x 10" x 1" deep, stainless steel bubbler, fast drain with air vent, elbow waste (1 1/2" FIP) and factory

provided single temperature pneumatic self-closing valve. Valve is chase mounted by contractor.

Cabinet interior shall be sound deadened with fire-resistant material.

Anchoring shall be by standard 4-point system: 1/2" threaded rods, nuts and washers shall be furnished for walls up to 8" thick. Unit shall require chase area for installation and maintenance.

*Made In The U.S.A.*



*Visit our website at <http://www.willoughby-ind.com>*

2210 West Morris Street • P.O. Box 21217 • Indianapolis, IN 46221

(317) 638-2381 • Fax: (317) 638-6110 • (800) 428-4065

