

ETW-1445-BS-HC Handicap Water Closet For Use On A 45 Degree Pipe Chase Blowout Series

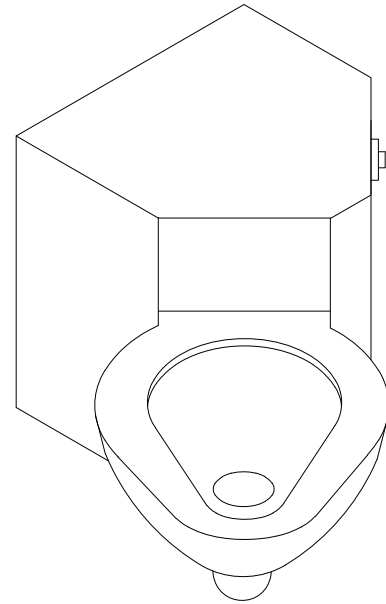

✓	MODEL NUMBER	FIXTURE BASE LOCATION
	ETW-1445-FM-BS-HC	ON FLOOR
	ETW-1445-OF-BS-HC	OFF FLOOR

Recommended Specifications

Toilet shall be Willoughby Model No. **ETW-1445-__-BS-HC** (select from table above).

Fixture shall be fabricated from 14 gauge, type 304 stainless steel. The construction shall be all-welded, with exposed stainless surfaces polished to a #4 satin finish.

Standard toilet shall include: elongated toilet bowl with contoured seat, integral crevice-free self-draining flushing rim with positive afterfill and fully enclosed 2 1/2" O.D. trap which shall maintain a minimum 2" seal and pass a 2 1/8" ball. Toilet shall be blowout type which requires 35 psi minimum flushing pressure.

Fixture shall withstand loadings up to 2,000 lbs. with no measurable deflection and loadings up to 5,000 lbs. with no permanent damage.

Anchoring shall be by standard 4-point system: threaded rods, nuts and washers shall be furnished for walls up to 8" thick. Unit shall require chase area for installation and maintenance.

Note: For 3 1/2 gallon flush, unit will pass a 2 5/8" ball.

On back to back fixture installations, do not use standard cross type waste fittings: cross flow may result due to blowout jet action. Use sanitary or offset type waste fittings.

Made In The **U.S.A.**



Visit our website at <http://www.willoughby-ind.com>

2210 West Morris Street • P.O. Box 21217 • Indianapolis, IN 46221
(317) 638-2381 • Fax: (317) 638-6110 • (800) 428-4065

MODEL NUMBER AND OPTIONS:

1.) Toilet Waste Location:

ETW Wall, Blowout

2.) Base Model Number:

1445-R Bowl on right side

1445-L Bowl on left side

3.) Fixture Mounting:

FM Floor Mounted

OF Off-Floor Mounted

4.) Inlet Location:

BS Back Spud

5.) Fixture Type:

HC Handicap Height

6.) Flush Valve GPF's (Must Specify):

-1.6 GPF (Low Consumption)

-3.5 GPF

7.) Toilet Waste:

TWE Toilet Waste Extension

TW1 No-Hub Waste w/ 3" Clean-out (Requires Flanged Unit)

TW2 No-Hub Waste w/o Clean-out (Requires Flanged Unit)

TW3 Coupling & 3" Clean-out for TWE

TW5 Coupling & 4" Clean-out for TWE

PC3 Pinned Clean-out Plug PVC-3"

PCB3 Pinned Clean-out Plug Brass-3"

PC4 Pinned Clean-out Plug PVC-4"

PCB4 Pinned Clean-out Plug Brass-4"

WO3 3" Toilet P-Trap (3.5 GPF Only)

COH Clean-out Hook

GW Gasketed Waste

8.) Options:

FV Flush Valve

FVT Flush Valve Connection

AP Flush Valve Access Panel

HS Hinged Plastic Seat

Black

White

HPS High Polish Seat

MT Metal Template

RTH1 Wall Mounted Recessed Tissue Holder

RTH2 Wall Mounted Recessed Tissue Holder (Front Access)

T4 Manual Reset Toilet Overflow Preventer (Requires Hydraulic Flush Valve)

T4A Auto Reset Toilet Overflow Preventer (Requires Hydraulic Flush Valve)

WS Wall Sleeve

TSC Toilet Shipping Cover

Other: _____

Other: _____

Drawing Approved For Manufacturing By: _____ Date: _____ Company: _____

Wall Thickness _____ Wall Type _____

(RIGHT HAND UNIT SYMMETRICALLY OPPOSITE)

IN COMPLIANCE WITH A.D.A. 1990

1.6 GPF OF VERSION SHOWN

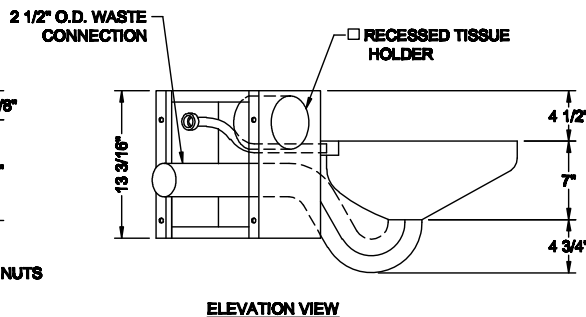
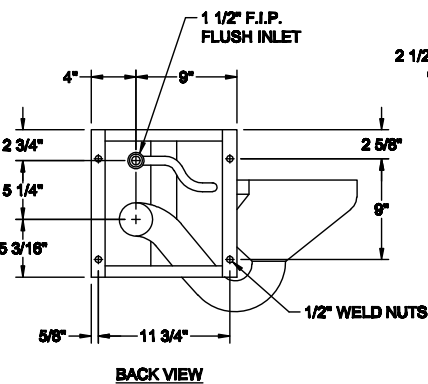
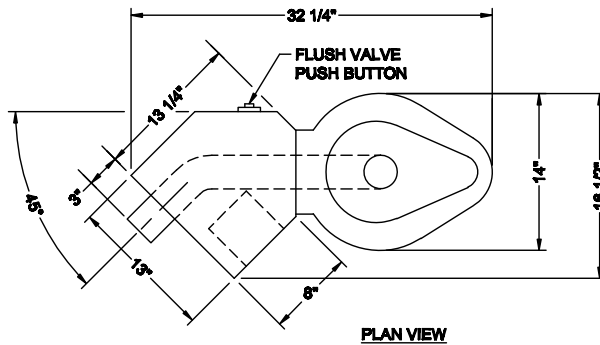

VERIFY ALL DIMENSIONS PRIOR TO ROUGH-IN

To specify fixture and accessories, use the Model Number and Options Guide.
 Example: To specify an ETW-1445-FM-BS-HC handicap floor mounted backspud, 1.6 GPF, toilet with high polish seat. Use the following Willoughby Model number:
 Willoughby Model Number: ETW-1445-FM-BS-1.6-HC-HPS



Made In The U.S.A.

Willoughby Industries, Inc.