

ETWS-1490-OF Off Floor Siphon Jet Series Water Closet

✓	MODEL NUMBER	INLET LOCATION
	ETWS-1490-OF-BS	BACK
	ETWS-1490-OF-TS	TOP

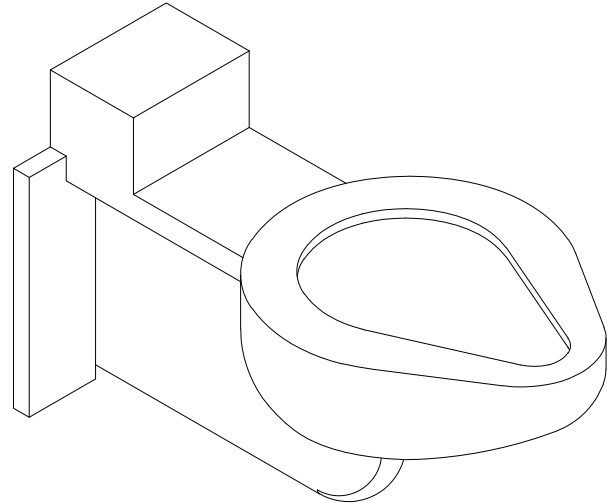

Recommended Specifications

Toilet shall be Willoughby Model No. **ETWS-1490-OF-___** (select from table above).

Fixture shall be fabricated from 14 gauge, type 304 stainless steel. The construction shall be all-welded, with exposed stainless surfaces polished to a #4 satin finish.

Standard toilet shall include: elongated toilet bowl with contoured seat, integral crevice-free self-draining flushing rim with positive afterfill and fully enclosed 2 1/2" O.D. trap which shall maintain a minimum 2" seal and pass a 2 1/8" ball. Toilet shall be siphon jet type which requires 35 psi minimum flushing pressure.

Fixture shall withstand loadings up to 2,000 lbs. with no measurable deflection and loadings up to 5,000 lbs. with no permanent damage.

Anchoring shall be by standard 4-point system: threaded rods, nuts and washers shall be furnished for walls up to 8" thick. Unit shall require chase area for installation and maintenance.

Note: For 3 1/2 gallon flush, unit will pass a 2 5/8" ball.

On back to back fixture installations, do not use standard cross type waste fittings: cross flow may result due to blowout jet action. Use sanitary or offset type waste fittings.

Made In The **U.S.A.**



Visit our website at <http://www.willoughby-ind.com>

2210 West Morris Street • P.O. Box 21217 • Indianapolis, IN 46221
(317) 638-2381 • Fax: (317) 638-6110 • (800) 428-4065

MODEL NUMBER AND OPTIONS:

1.) Toilet Waste Location:

ETWS Wall, Siphon Jet

2.) Base Model Number:

1490

3.) Fixture Mounting:

OF Off Floor

4.) Inlet Location:

BS Back Spud

TS Top Spud

5.) Flush Valve GPF's (Must Specify):

-1.6 GPF (Low Consumption)

-3.5 GPF

6.) Toilet Waste:

TWE Toilet Waste Extension

TW1 No-Hub Waste w/ 3" Clean-out (Requires Flanged Unit)

TW2 No-Hub Waste w/o Clean-out (Requires Flanged Unit)

TW3 Coupling & 3" Clean-out for TWE

TW5 Coupling & 4" Clean-out for TWE

PC3 Pinned Clean-out Plug PVC-3"

PCB3 Pinned Clean-out Plug Brass-3"

PC4 Pinned Clean-out Plug PVC-4"

PCB4 Pinned Clean-out Plug Brass-4"

WO3 3" Toilet P-Trap (3.5 GPF Only)

COH Clean-out Hook

GW Gasketed Waste

7.) Options:

FV Flush Valve

FVC Flush Valve Cover (Top Spud)

FVT Flush Valve Connection

AP Flush Valve Access Panel

HS Hinged Plastic Seat

Black

White

HPS High Polish Seat

MT Metal Template

RTH1 Wall Mounted Recessed Tissue Holder

RTH2 Wall Mounted Recessed Tissue Holder (Front Access)

T4 Manual Reset Toilet Overflow Preventer (Requires Hydraulic Flush Valve)

T4A Auto Reset Toilet Overflow Preventer (Requires Hydraulic Flush Valve)

WS Wall Sleeve

TSC Toilet Shipping Cover

Other: _____

Other: _____

Drawing Approved For Manufacturing By: _____ Date: _____ Company: _____
 Wall Thickness _____ Wall Type _____

