

T4 Toilet Overflow Preventer

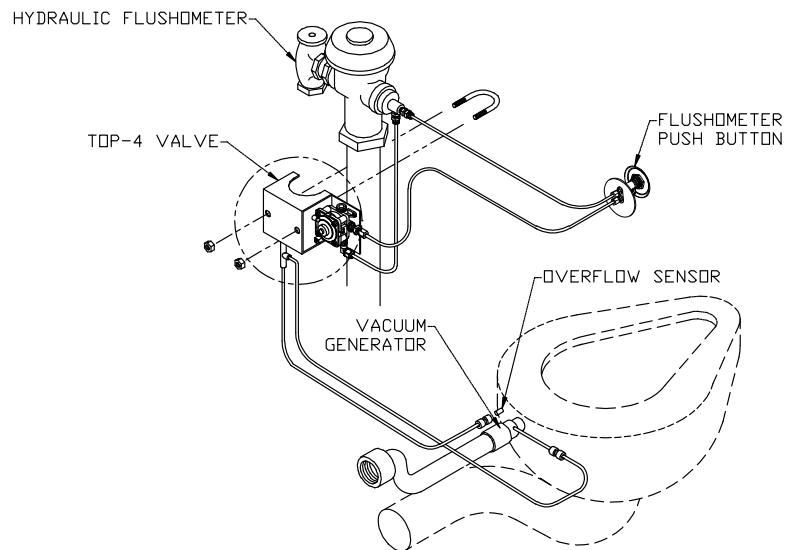

Recommended Specifications

Toilet overflow preventer shall be Willoughby Model No. **T4**.

The toilet overflow preventer shall be installed on a Willoughby toilet or combination toilet/lavatory fixture to prevent overflow. The unit shall consist of a vacuum operated disabler, a vacuum generator and an overflow sensor. The vacuum generator and overflow sensor shall be factory installed in all specially modified fixtures. The disabler valve shall be installed in the control circuit of a hydraulic flushometer. Vacuum connections between the disabler valve and the fixture shall be polyethylene tubing. After a backup, the unit shall be manually reset by a push button on the disabler valve. The unit shall allow no overflow and require no outside power source.

Operation

During each flush cycle, water flowing through the fixture produces a vacuum at the vacuum generator. Normally, this vacuum is drawn unrestricted through the overflow sensor. Should the water level in the bowl rise due to in-

tentional blocking of the drain or a clog downstream of the fixture, it will cover the opening of the sensor. When water is drawn into the sensor, the majority of the vacuum will be redirected to the disabler valve. The disabler valve is normally open vacuum operated valve installed in the control circuit of a hydraulic flushometer. The vacuum closes the disabler valve thereby preventing any additional flushes until the unit is manually reset.

Application

The toilet overflow preventer is recommended for facilities with high vandalism (prisons, parks, schools, etc.) and is normally used in conjunction with a back supply toilet or combination unit where an accessible pipe chase is provided.

Made In The **U.S.A.**



Visit our website at <http://www.willoughby-ind.com>

2210 West Morris Street • P.O. Box 21217 • Indianapolis, IN 46221
(317) 638-2381 • Fax: (317) 638-6110 • (800) 428-4065