

T4A Toilet Overflow Preventer with Auto-reset

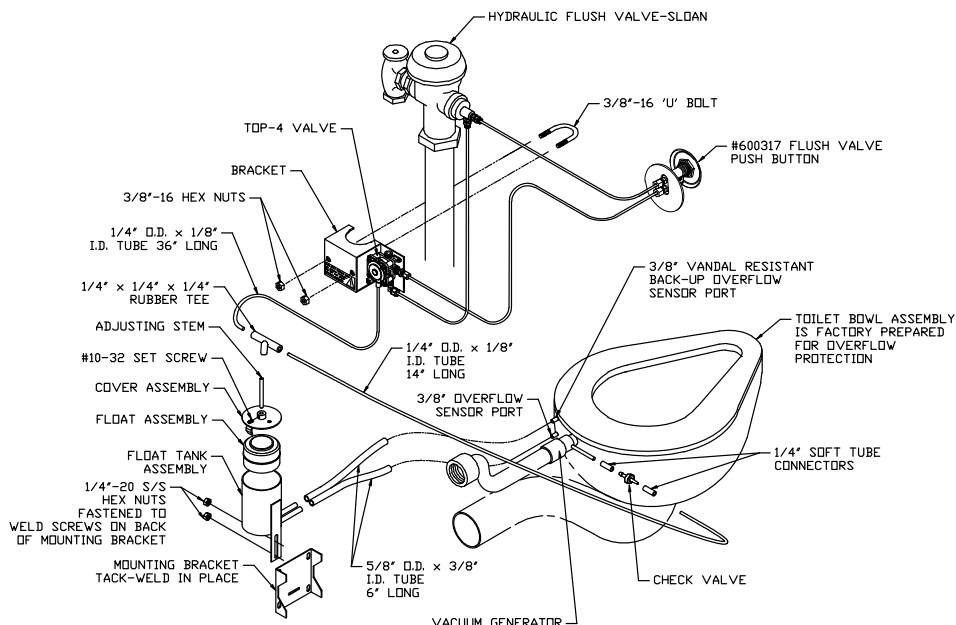

Recommended Specifications

Toilet overflow preventer shall be Willoughby Model No. **T4A**.

The toilet overflow preventer shall be installed on a Willoughby toilet or combination toilet/lavatory fixture to prevent overflow. The unit shall consist of a vacuum operated disabler, a vacuum generator, an overflow sensor, and a float sensor canister. The vacuum generator and overflow sensor shall be factory installed in all specially modified fixtures. The disabler valve shall be installed in the control circuit of a hydraulic flushometer. Vacuum connections between the disabler valve and the fixture shall be polyethylene tubing. After a backup, the unit shall automatically reset by the lowering of the water in the toilet bowl to normal level. The unit shall allow no overflow and require no outside power source.

Operation

During each flush cycle, water flowing through the fixture produces a vacuum at the vacuum generator. Normally, this vacuum is drawn unrestricted through the overflow sensor. Should the water level in the bowl rise due to intentional blockage or down stream obstruction, water covers the overflow sensor port and fills the float canister. The float rises and directs the vacuum to the disabler valve.

The disabler valve is normally open vacuum operated valve installed in the control circuit of a hydraulic flushometer. The vacuum closes the disabler valve thereby preventing any additional flushes until the water level in the toilet bowl returns to normal. When the water level drops, the float canister drains back to the toilet bowl lowering the float. Once the float lowers to its normal position it permits air to enter the system opening the disabler valve and allows normal flush operation.

Application

The toilet overflow preventer is recommended for facilities with high vandalism (prisons, parks, schools, etc.) and is normally used in conjunction with a back supply toilet or combination unit where an accessible pipe chase is provided.

Made In The **U.S.A.**



Visit our website at <http://www.willoughby-ind.com>

2210 West Morris Street • P.O. Box 21217 • Indianapolis, IN 46221

(317) 638-2381 • Fax: (317) 638-6110 • (800) 428-4065