

## UW-1412-BJ Series Straddle Urinal Blowout Type

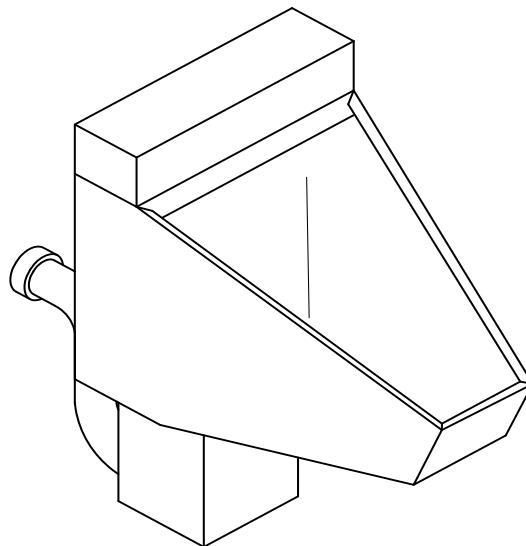

✓	MODEL NUMBER	FLUSH TYPE	INLET LOCATION
	UW-1412-BJ-BS	BLOWOUT	BACK
	UW-1412-BJ-TS	BLOWOUT	TOP

### Recommended Specifications

---

Wall hung straddle urinal shall be Willoughby Model No. **UW-1412-BJ-\_\_** (select from table above).

Fixture shall be fabricated from 14 gauge, type 304 stainless steel. The construction shall be all-welded, with exposed stainless surfaces polished to a #4 satin finish.

Standard equipment shall include: full perimeter 360 degree flushing rim and integral stainless steel p-trap. Urinal shall be blowout type which requires 25 psi minimum flushing pressure. Trap shall be fully enclosed, maintain a 3" seal and pass a 1.9" ball.

Anchoring shall be by standard 4-point system: threaded rods, nuts and washers furnished for walls up to 8" thick. Unit requires chase area for installation and maintenance.

*Made In The U.S.A.*



*Visit our website at <http://www.willoughby-ind.com>*

2210 West Morris Street • P.O. Box 21217 • Indianapolis, IN 46221  
(317) 638-2381 • Fax: (317) 638-6110 • (800) 428-4065

## MODEL NUMBER AND OPTIONS:

**1.) Urinal Waste Location:**

UW Wall Outlet

**2.) Base Model Number:**

1412 Straddle Urinal

**3.) Flush Type:**

BJ Blow-Jet

**4.) Inlet Location:**

BS Back Spud

TS Top Spud

**5.) Options:**

MT Metal Template

WS Wall Sleeve

FV Flush Valve

FVC Flush Valve Cover (Top Spud)

FVT Flush Valve Thru-Wall Connection  
(Requires Back Spud Option)

AP Flush Valve Access Panel

Other: \_\_\_\_\_

Other: \_\_\_\_\_

Drawing Approved For Manufacturing By: \_\_\_\_\_ Date: \_\_\_\_\_ Company: \_\_\_\_\_  
 Wall Thickness: \_\_\_\_\_ Wall Type: \_\_\_\_\_

**VERIFY ALL DIMENSIONS PRIOR TO ROUGH-IN**

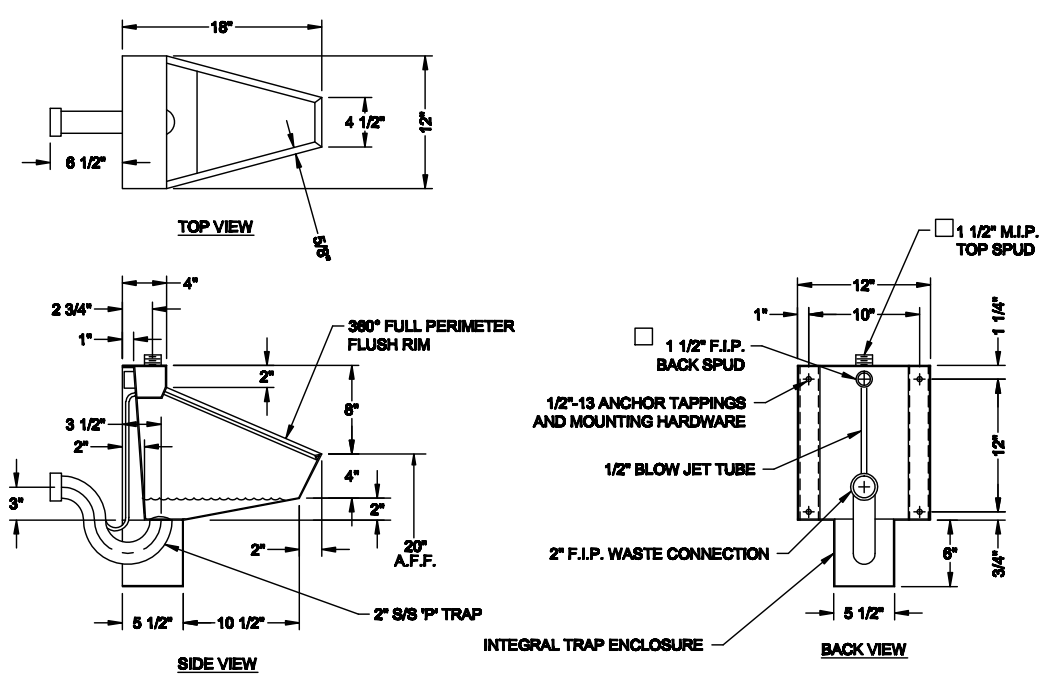

**To specify fixture and accessories, use the Model Number / Options Guide.**  
 Example: To specify a UW-1412-BJ straddle urinal with back spud.  
 Use the following Willoughby Model Number:  
 Willoughby Model Number: UW-1412-BJ-BS



Made In The U.S.A.

# Willoughby Industries, Inc.