

BETW-1490-FM-FA Front Access Wall Outlet Blowout Series Bariatric Toilet

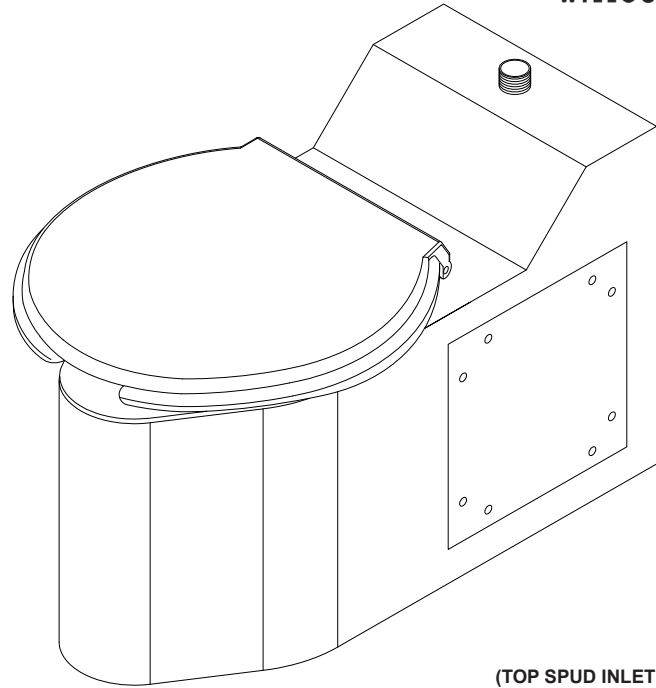

(TOP SPUD INLET SHOWN)



To specify fixture and accessories, use the Model Number and Options page.

Example: To specify a Front Access, Wall Outlet, Blowout Series Bariatric Toilet with back spud, flush valve and wall mounted recessed tissue holder

Use the following Willoughby Model Number:

BETW-1490-FM-FA-BS-FV-RTH1

Recommended Specifications

Front Access, Wall Outlet, Blowout Series Bariatric Toilet shall be: Willoughby Model No. **BETW-1490-FM-FA** (Select from model number and options list on next page)

Fixture shall be fabricated from heavy gauge, Type 304 stainless steel. The construction shall be all-welded. Fixture exterior shall have an antimicrobial gloss white powder coat enamel finish*. Toilet bowl interior shall have a sanitary bead-blast stainless steel finish.

Standard toilet shall include: elongated toilet bowl with integral contoured seat, integral crevice-free self-draining flushing rim with positive afterfill and fully enclosed 2-1/2" O.D. trap which shall maintain a minimum 3-1/2" seal and pass a 2-1/8" ball. Toilet shall be siphon jet type which requires 35 psi minimum flushing pressure. Hinged toilet seat shall have open front with cover and be rated for a 1200 pound weight capacity. Toilet seat hinges are stainless steel, seat and cover shall be white in color.

The fixture (less hinged seat) shall withstand loadings up to 2000 pounds with no measurable deflection and loadings up to 5000 pounds with no permanent damage.

Anchoring shall be from the front thru (2) 12" x 12" removable access panels. The fixture is provided with three (3) 7/8" wall carrier mounting holes and one (1) floor mounted 'Z' clip mounting bracket. Wall and floor anchoring hardware is by others. The fixture is floor mounted and is designed to mate with a three (3) bolt blowout carrier.

On back to back fixture installations, do not use standard cross type waste fittings: cross flow may result due to blowout jet action. Use sanitary or offset type waste fittings.

**Antimicrobial properties are built-in to inhibit the growth of bacteria that may affect this product. The antimicrobial properties do not protect users or others against bacteria, viruses, germs, or other disease organisms. Always use good hygienic cleaning practices.*

visit our website at www.willoughby-ind.com
5105 West 78th Street • Indianapolis, IN. 46268
(317) 875-0830 • Fax: (317) 875-0837 • (800) 428-4065



MADE IN THE U.S.A.

MODEL NUMBER AND OPTIONS:

1.) Base Model Number:

BETW-1490-FM-FA Front Access, Wall Outlet, Blowout Series Bariatric Toilet

2.) Inlet Location:

BS Back Spud
 TS Top Spud

3.) Flush Valve GPF's (Must Specify):

1.28 GPF HET
 1.6 GPF ULF (Standard)
 3.5 GPF (3" Waste Tube Required)

4.) Options:

BL Bedpan Lugs
 SLL Seat Less Lid
 FV Flush Valve
 ASFVCADA Ligature-resistant ADA Flush Valve Cover (Top Spud Only)
 FVT Flush Valve Connection
 AP Flush Valve Access Panel
 MT Metal Template
 RTH2 Front Access Wall Mounted Recessed Tissue Holder
 Other: _____
 Other: _____

Approved For Manufacturing By: _____ Date: _____ Company: _____
 Wall Thickness: _____ Wall Type: _____

VERIFY ALL DIMENSIONS WITH FACTORY PRIOR TO ROUGH-IN
 WILLOUGHBY RESERVES THE RIGHT TO MAKE CHANGES IN DESIGN AND DIMENSIONS WITHOUT FORMAL NOTICE AND WITHOUT INCURRING OBLIGATION.

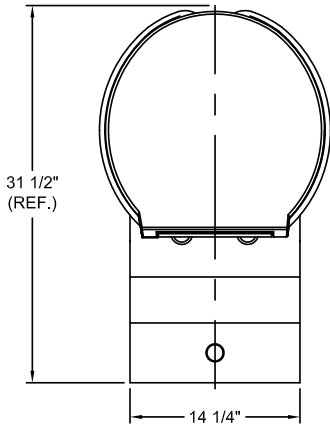

 IN COMPLIANCE WITH A.D.A. 2010

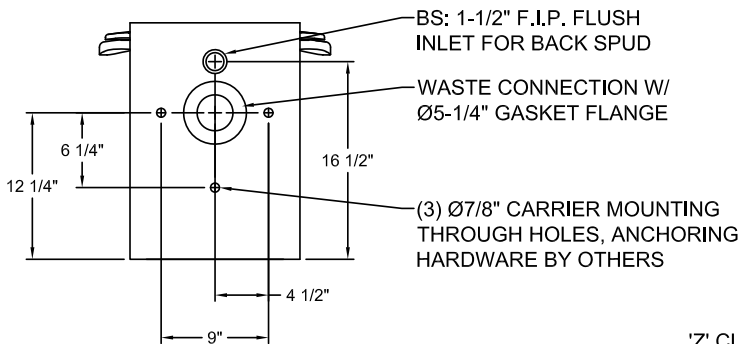
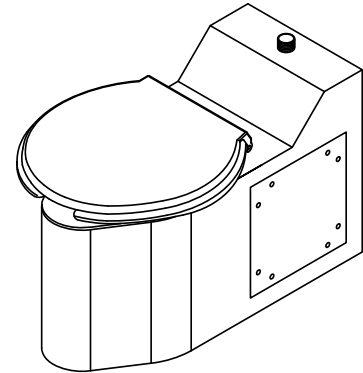

TS: 1-1/2" M.I.P. FLUSH INLET FOR TOP SPUD

12" x 12" ACCESS PANEL (BOTH SIDES)

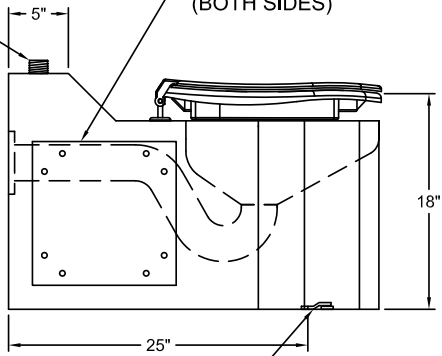

visit our website at www.willoughby-ind.com
 5105 West 78th Street • Indianapolis, IN. 46268
 (317) 875-0830 • Fax: (317) 875-0837 • (800) 428-4065



MADE IN THE U.S.A.