

## DF-1013-96 Rear Mounted Drinking Fountain

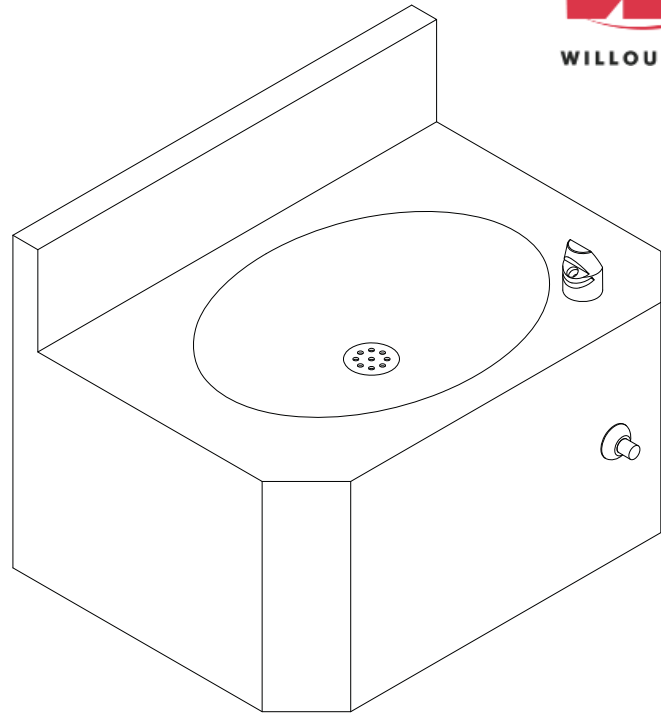

*(Unit may be shown with optional features)*

To specify fixture and accessories, use the Model Number and Options page.

Example: To specify a Rear Mounted Drinking Fountain with standard drinking fountain bubbler, standard single temp. non-metering pneumatic valve and push button, and standard elbow waste

Use the following Willoughby Model Number:

DF-1013-96-DB-PSL1-PPB-EB

## Recommended Specifications

Rear Mounted Drinking Fountain shall be:  
Willoughby Model No. **DF-1013-96**  
(select from model number and options list on next page)

Fixture shall be fabricated from 14 gauge, type 304 stainless steel. The construction shall be all-welded, with exposed stainless surfaces polished to a #4 satin finish.

Standard equipment shall include:

- Oval basin, 13" x 9-1/2" x 1-1/2" deep
- Integral fast drain with air vent
- (DB) stainless steel drinking fountain bubbler
- (PSL1) Single temperature, non-metering pneumatic valve w/ (PPB) push button
- (EB) elbow waste (1-1/2" F.I.P.)

Cabinet interior shall be sound deadened with fire-resistant material.

### Mounting:

Anchoring shall be by standard 4-point system: 1/2" threaded rods, nuts and washers shall be furnished for walls up to 8" thick.

Unit shall require chase area for installation and maintenance.

### Vandal Resistance:

All push buttons and escutcheons are secured to the unit from within the fixture. Valves, water supplies, and waste connections are concealed within.

visit our website at [www.willoughby-ind.com](http://www.willoughby-ind.com)

5105 West 78th Street • Indianapolis, IN. 46268  
(317) 875-0830 • Fax: (317) 875-0837 • (800) 428-4065



MADE IN THE U.S.A.

# MODEL NUMBER AND OPTIONS:

**1.) Drinking Fountain Model:**

DF-1013-96 Drinking Fountain

**2.) Bubbler Selection:**

DB Drinking Fountain Bubbler (Standard)

**3.) Valve Selection:**

PSL1 Single Temp. Pneumatic Non-metering (Standard)

**4.) Push Button Selection:**

PPB Pneumatic Push Button (Standard)

**5.) Drinking Fountain Waste:**

- EB Elbow Waste (Standard)
- PT Integral 'P'-Trap
- LW1 Lavatory Waste Extension
- LW2 Thru-Wall Extension, 'P'-Trap and Clean-Out

**6.) Other Options:**

- MT Wall Template
- WS Wall Sleeve (Requires Accessible Chase)
- Other: \_\_\_\_\_
- Other: \_\_\_\_\_

Approved For Manufacturing By: \_\_\_\_\_ Date: \_\_\_\_\_ Company: \_\_\_\_\_  
 Wall Thickness: \_\_\_\_\_ Wall Type: \_\_\_\_\_

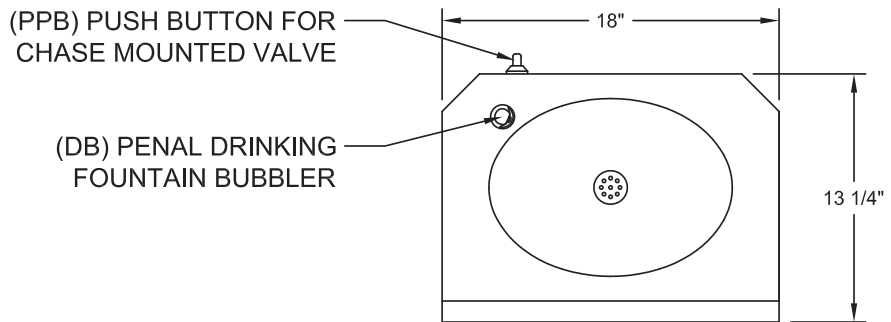

PLAN VIEW

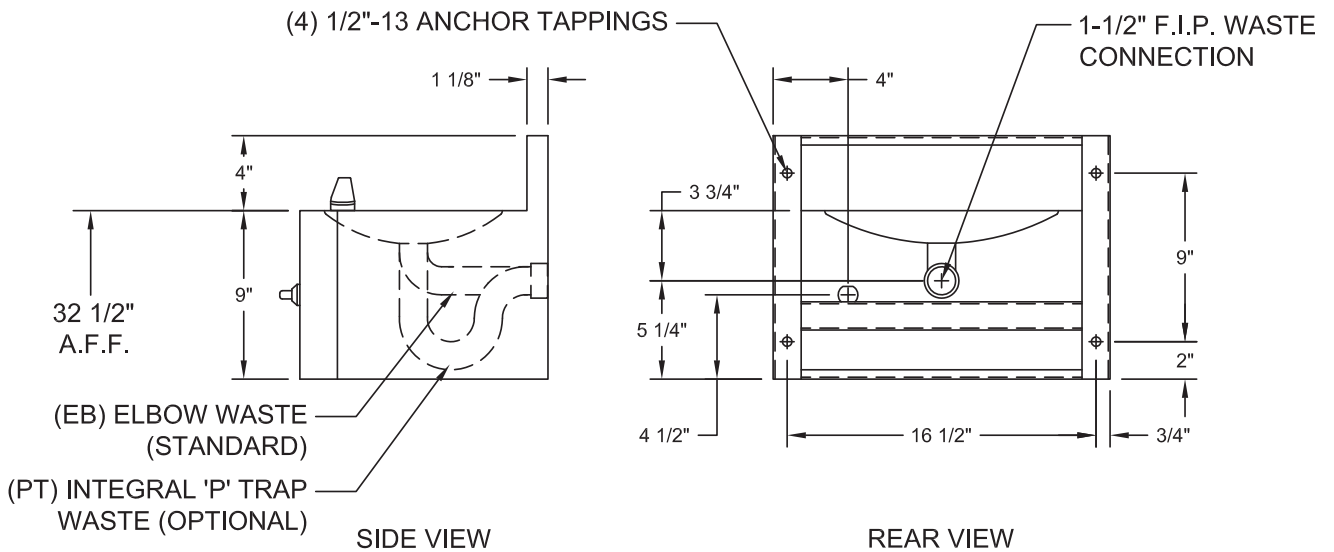

SIDE VIEW

REAR VIEW

**VERIFY ALL DIMENSIONS WITH FACTORY PRIOR TO ROUGH-IN**  
 WILLOUGHBY RESERVES THE RIGHT TO MAKE CHANGES IN DESIGN AND DIMENSIONS WITHOUT FORMAL NOTICE AND WITHOUT INCURRING OBLIGATION.

*visit our website at [www.willoughby-ind.com](http://www.willoughby-ind.com)*  
 5105 West 78th Street • Indianapolis, IN. 46268  
 (317) 875-0830 • Fax: (317) 875-0837 • (800) 428-4065



MADE IN THE U.S.A.