

## DF-1015-96-HC Handicap-ADA Compliant Rear Mounted Drinking Fountain

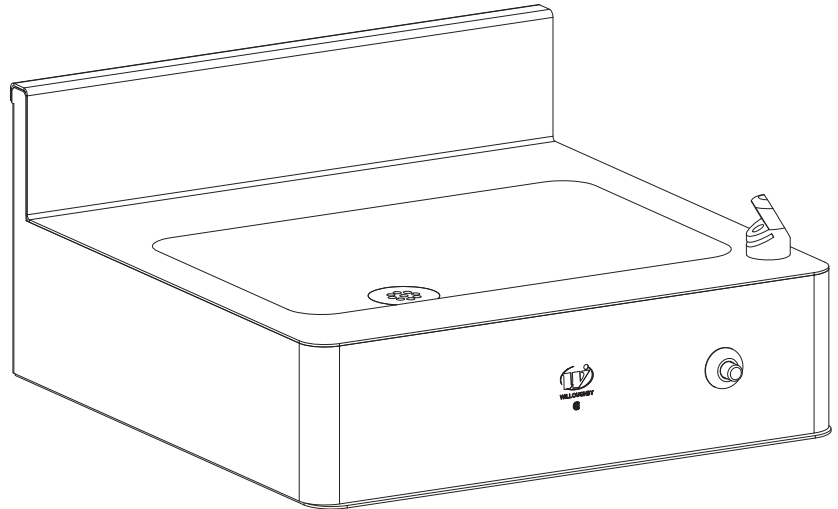

*(Unit may be shown with optional features)*

To specify fixture and accessories, use the Model Number and Options page.  
Example: To specify a Handicap-ADA Compliant, Rear Mounted Drinking Fountain with standard drinking fountain bubbler, standard single temp. non-metering pneumatic valve and push button, and standard elbow waste  
Use the following Willoughby Model Number:  
**DF-1015-96-HC-DB-PSL1-PPB-EB**

### Recommended Specifications

Handicap-ADA Compliant, Rear Mounted Drinking Fountain shall be: Willoughby Model No. **DF-1015-96-HC**  
(select from model number and options list on next page)

Fixture shall be fabricated from 14 gauge, type 304 stainless steel. The construction shall be all-welded, with exposed stainless surfaces polished to a #4 satin finish.

Standard equipment shall include:

- Oval basin, 13" x 9-1/2" x 1-1/2" deep
- Integral fast drain with air vent
- (DB) stainless steel drinking fountain bubbler
- (PSL1) Single temperature, non-metering pneumatic valve w/ (PPB) push button
- (EB) elbow waste (1-1/2" F.I.P.)

Cabinet interior shall be sound deadened with fire-resistant material.

#### Mounting:

Anchoring shall be by standard 4-point system: 1/2" threaded rods, nuts and washers shall be furnished for walls up to 8" thick.

Unit shall require chase area for installation and maintenance.

#### Vandal Resistance:

All push buttons and escutcheons are secured to the unit from within the fixture. Valves, water supplies, and waste connections are concealed within.

# MODEL NUMBER AND OPTIONS:

## 1.) Drinking Fountain Model:

- DF-1015-96-HC Handicap-ADA Compliant, Rear Mounted Drinking Fountain

## 2.) Bubbler Selection:

- DB Drinking Fountain Bubbler (Standard)

## 3.) Valve Selection:

- PSL1 Single Temp. Pneumatic Non-metering (Standard)

## 4.) Push Button Selection:

- PPB Pneumatic Push Button (Standard)

## 5.) Drinking Fountain Waste:

- EB Elbow Waste (Standard)  
 PT Integral 'P'-Trap  
 LW1 Lavatory Waste Extension  
 LW1 Thru-Wall Extension, 'P'-Trap and Clean-Out

## 6.) Other Options:

- MT Wall Template  
 WS Wall Sleeve (Requires Accessible Chase)  
 Other: \_\_\_\_\_  
 Other: \_\_\_\_\_

Approved For Manufacturing By: \_\_\_\_\_ Date: \_\_\_\_\_ Company: \_\_\_\_\_  
 Wall Thickness: \_\_\_\_\_ Wall Type: \_\_\_\_\_

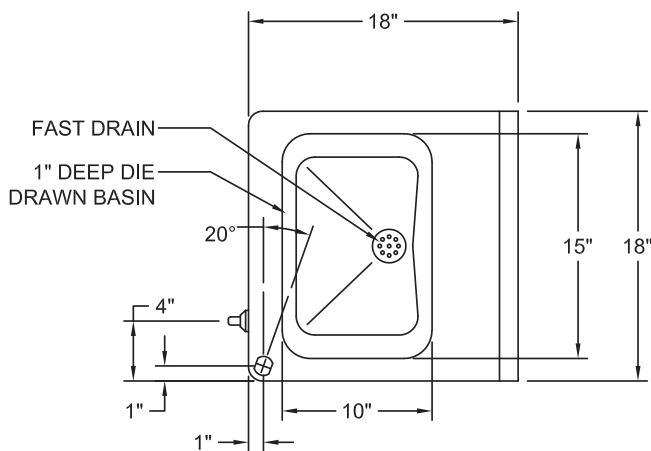

PLAN VIEW



### NOTE:

33" RIM HEIGHT SHOWN, 34" BUBBLER (34" AND 36" MAX ADULT ADA HEIGHTS, RESPECTIVELY) ADJUST DIMENSIONS ACCORDINGLY FOR ALTERNATE HEIGHTS

VERIFY ALL DIMENSIONS WITH FACTORY PRIOR TO ROUGH-IN  
 WILLOUGHBY RESERVES THE RIGHT TO MAKE CHANGES IN DESIGN AND DIMENSIONS WITHOUT FORMAL NOTICE AND WITHOUT INCURRING OBLIGATION.

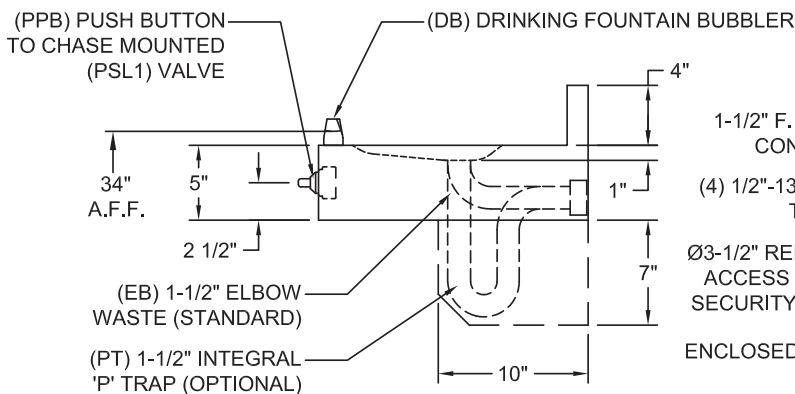

SIDE VIEW

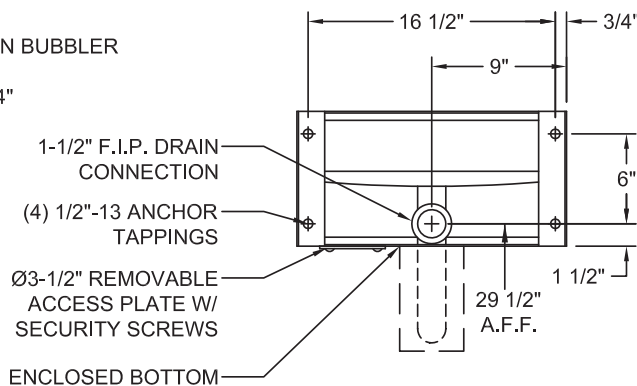

REAR VIEW

visit our website at [www.willoughby-ind.com](http://www.willoughby-ind.com)  
 5105 West 78th Street • Indianapolis, IN. 46268  
 (317) 875-0830 • Fax: (317) 875-0837 • (800) 428-4065



MADE IN THE U.S.A.