

DF-1812-FA Small Profile Handicap-ADA Compliant Front Access Drinking Fountain

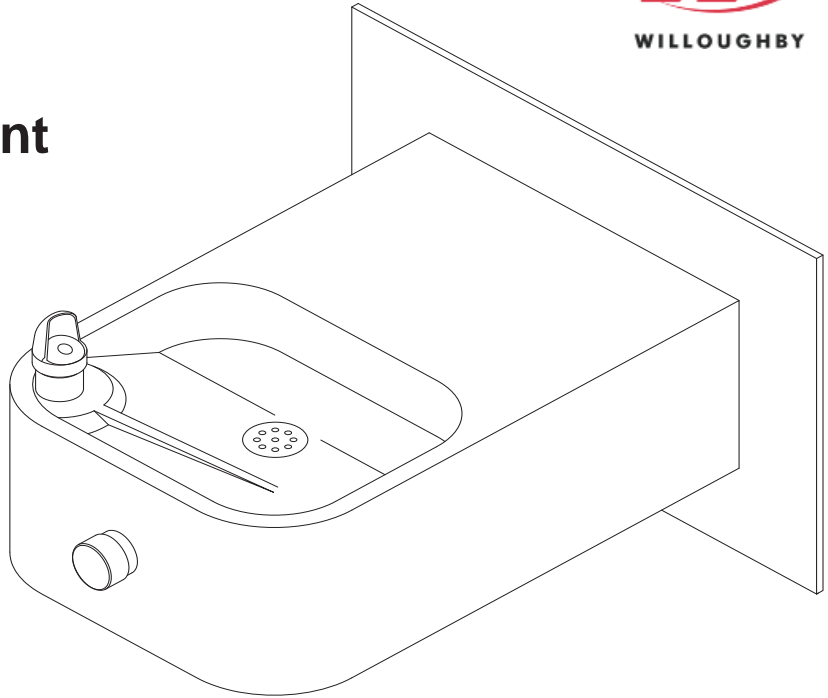

(Unit may be shown with optional features)



IN COMPLIANCE
WITH A.D.A. 2010

To specify fixture and accessories, use the Model Number and Options page.

Example: To specify a Small Profile, Handicap-ADA Compliant, Front Access Drinking Fountain with standard drinking fountain bubbler, standard single temp. non-metering pneumatic valve and push button, standard removable 'p'-trap, and s/s wall back-panel

Use the following Willoughby Model Number:

DF-1812-FA-CDB-PSL1-PLPB-RPT-WPB

Recommended Specifications

Small Profile, Handicap-ADA Compliant, Front Access Drinking Fountain shall be: Willoughby Model No. **DF-1812-FA** (select from model number and options list on next page)

Fixture shall be fabricated from 14 gauge, type 304 stainless steel. The construction shall be all-welded, with exposed stainless surfaces polished to a #4 satin finish.

Standard equipment shall include:

- Rectangular-shaped basin with rounded corners, 8-5/8" x 10-3/4" x 2" deep
- Removable stainless steel fast drain
- (CDB) stainless steel drinking fountain bubbler
- (PSL1) Single temperature, non-metering pneumatic valve w/ (PLPB) pneumatic palm push button
- (RPT) slip joint, cast brass union 'p'-trap (1-1/2")
- Removable bottom panel attached w/ vandal resistant screws

Cabinet interior shall be sound deadened with fire-resistant material.

Mounting:

Anchoring shall be from the front with mounting plate and attachment screws provided. Anchoring hardware by others.

Unit requires no chase area for installation and maintenance.

Vandal Resistance:

All push buttons and escutcheons are secured to the unit from within the fixture. Valves, water supplies and waste connections are concealed within. The bottom panel is removable and secured with vandal resistant security screws.

ADA and ANSI Compliant:

When the drinking fountain is mounted at standard 36" bubbler height, it is designed to comply with applicable ADA and ANSI Z124.3 and Z124.6 accessibility guidelines.

visit our website at www.willoughby-ind.com

5105 West 78th Street • Indianapolis, IN. 46268

(317) 875-0830 • Fax: (317) 875-0837 • (800) 428-4065



MADE IN THE U.S.A.

MODEL NUMBER AND OPTIONS:

1.) Drinking Fountain Model:

- DF-1812-FA Small Profile, Handicap-ADA Compliant, Front Access Drinking Fountain

2.) Bubbler Selection:

- CDB Drinking Fountain Bubbler (Standard)

3.) Valve Selection:

- PSL1 Single Temp. Pneumatic Non-metering (Standard)

4.) Push Button Selection:

- PLPB Pneumatic Palm Push Button (Standard)

5.) Drinking Fountain Waste:

- RPT Slip Joint, Cast Brass Union 'P'-trap (Removable, 1-1/2") (Standard)

6.) Other Options:

- MT Wall Template
 WBP Stainless Steel Wall Back-Panel
 Other: _____
 Other: _____

Approved For Manufacturing By: _____ Date: _____ Company: _____
 Wall Thickness: _____ Wall Type: _____

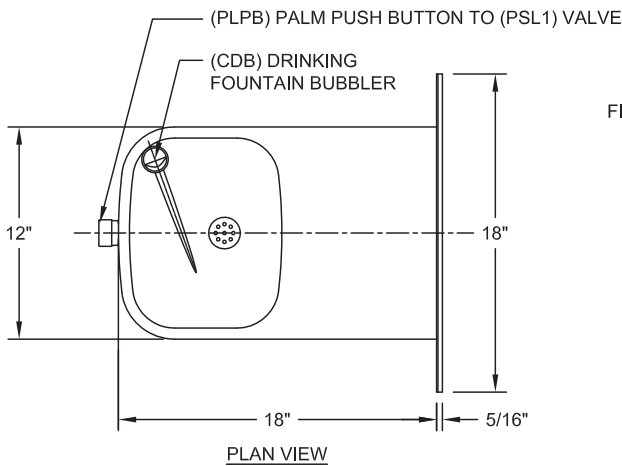

IN COMPLIANCE WITH A.D.A. 2010

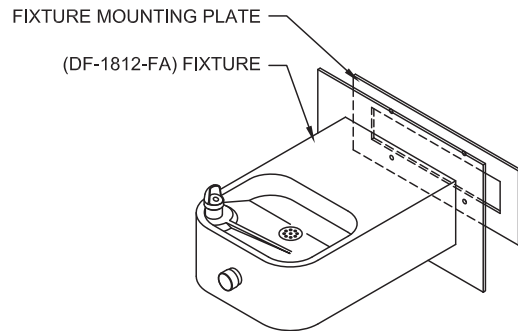

VERIFY ALL DIMENSIONS WITH FACTORY PRIOR TO ROUGH-IN
 WILLOUGHBY RESERVES THE RIGHT TO MAKE CHANGES IN DESIGN AND DIMENSIONS WITHOUT FORMAL NOTICE AND WITHOUT INCURRING OBLIGATION.

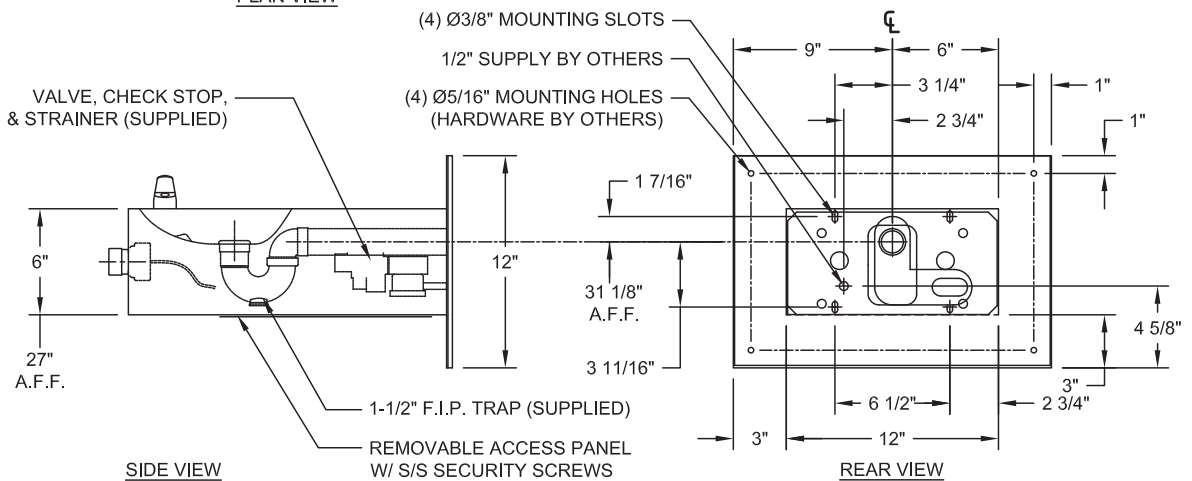

NOTE:
 33" RIM HEIGHT SHOWN, 34" BUBBLER (34" AND 36" MAX ADULT ADA HEIGHTS, RESPECTIVELY) ADJUST DIMENSIONS ACCORDINGLY FOR ALTERNATE HEIGHTS

visit our website at www.willoughby-ind.com
 5105 West 78th Street • Indianapolis, IN. 46268
 (317) 875-0830 • Fax: (317) 875-0837 • (800) 428-4065



MADE IN THE U.S.A.