

PML-BHF Lead-free Behavioral Healthcare Pneumatic Faucet

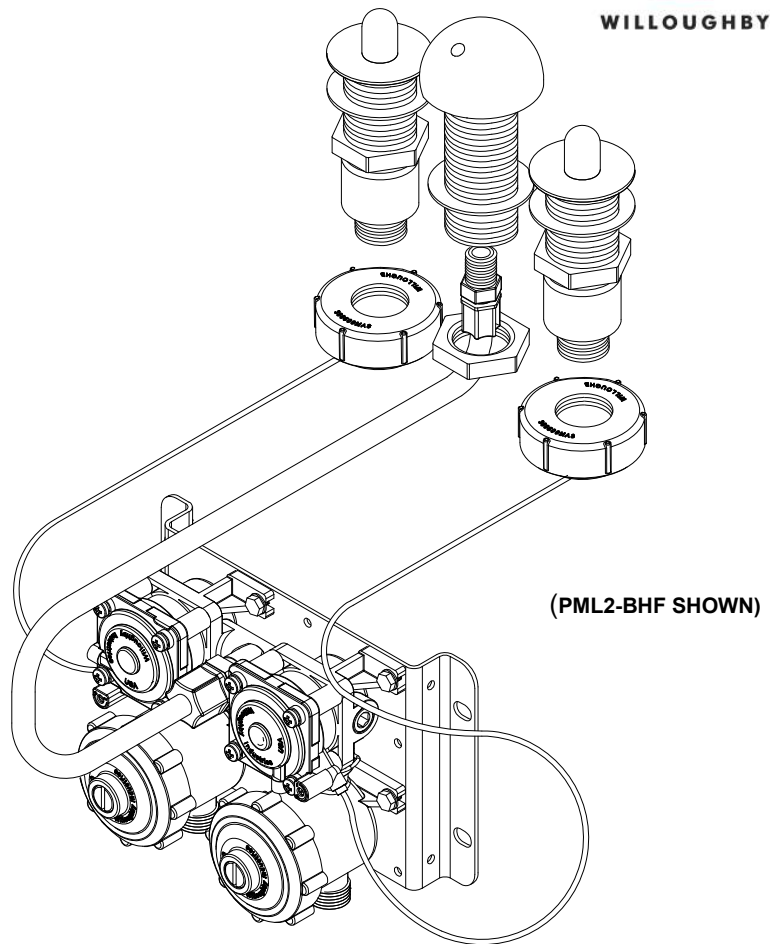

Recommended Specifications

Lead-free Behavioral Healthcare Pneumatic Faucet shall be:
Willoughby Model No. **PML-BHF**
(Select from options list on the following page)

The Behavioral Healthcare Faucet is designed to either retrofit existing lavatories or be specified for new design. Faucet shall be deck mounted, requiring (3) $\text{Ø}1\text{-}5/16\text{'}$ to $\text{Ø}1\text{-}1/2\text{'}$ faucet holes (faucet holes between 4" centerset to 8" centerset are recommended). Bubbler and push buttons shall be machined from T303 stainless steel and shall have ligature-resistant hemispherical designs.

Valve constructed of stainless steel and plastic materials and complies with NSF-61 standard. The valve assembly shall use a diaphragm to pneumatically activate a non-hold-open metering (5-90 second) pneumatic valve assembly. The push button shall require less than 5 lbs. of force to operate. Vandal resistant stainless steel push button and keyed pump body shall be non-removable from the top of the fixture deck. The valve flow is 0.5 GPM.

The plastic valve checkstop/strainer shall feature integral mounting points. Replaceable stainless steel strainer and optional 0.5 GPM flow control can be serviced without disturbing the supply line. Assembly shall use flexible tubing to connect to the filler/bubbler. Water inlet is $1/2\text{'}$ MPT and is reversible for either top or bottom supply. A galvanized wall mounting plate is provided, wall anchoring hardware provided by others.

Recommended operating pressure shall be 35-70 psi. Valve shall withstand pressures up to 90 psi. The maximum length for tubing between the push button actuator and the valve is 10 feet. The pneumatic system is entirely self-contained and shall require no outside air supply.

* The PML2 valve is not a substitute for a thermostatic mixing valve. In dual temperature valves, the delivered water temperature is the result of the two combined inlet temperatures and cannot be adjusted by this valve assembly. The hot side of the valve must be supplied with tempered water.

An In-line Thermostatic Mixing Valve (TMV) is available (select from options list on the following page).

visit our website at www.willoughby-ind.com
5105 West 78th Street • Indianapolis, IN. 46268
(317) 875-0830 • Fax: (317) 875-0837 • (800) 428-4065



MADE IN THE U.S.A.

MODEL NUMBER AND OPTIONS:

1.) Valve Selection: (Choose One)

- PML1-BHF Single Temperature Metering Valve
- PML2-BHF Dual Temperature Metering Valve

2.) Options:

- TMV In-line Thermostatic Mixing Valve

Approved For Manufacturing By: _____ Date: _____ Company: _____
 Wall Thickness: _____ Wall Type: _____

VERIFY ALL DIMENSIONS WITH FACTORY PRIOR TO ROUGH-IN
 WILLOUGHBY RESERVES THE RIGHT TO MAKE CHANGES IN DESIGN AND DIMENSIONS WITHOUT FORMAL NOTICE AND WITHOUT INCURRING OBLIGATION.

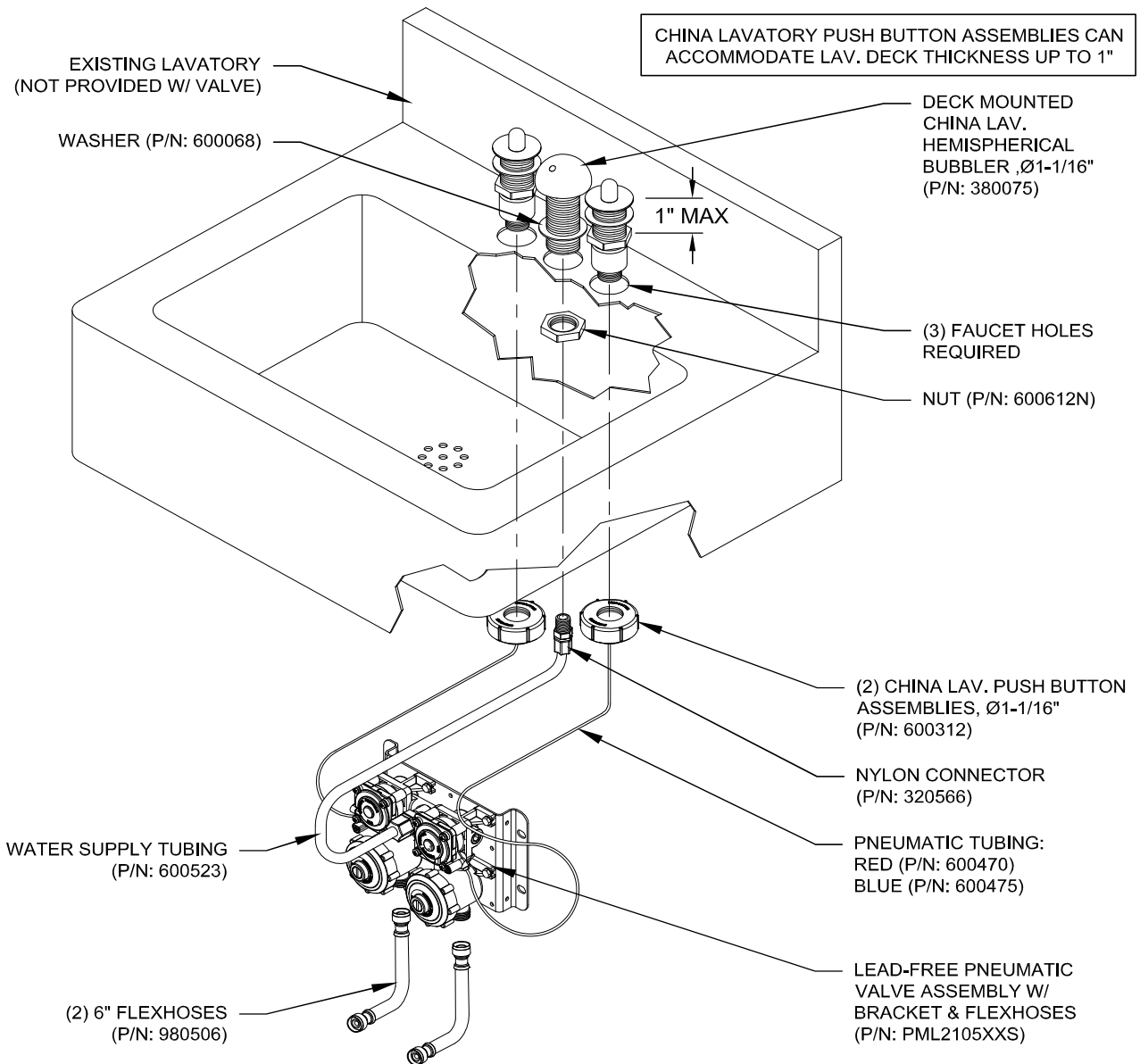

visit our website at www.willoughby-ind.com
 5105 West 78th Street • Indianapolis, IN. 46268
 (317) 875-0830 • Fax: (317) 875-0837 • (800) 428-4065



MADE IN THE U.S.A.