

WBDF-1519-HC-FA Ligature-resistant Front Access Stainless Steel Behavioral Drinking Fountain

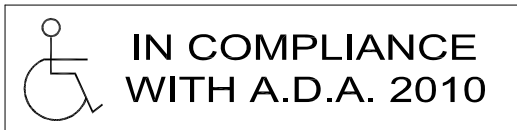
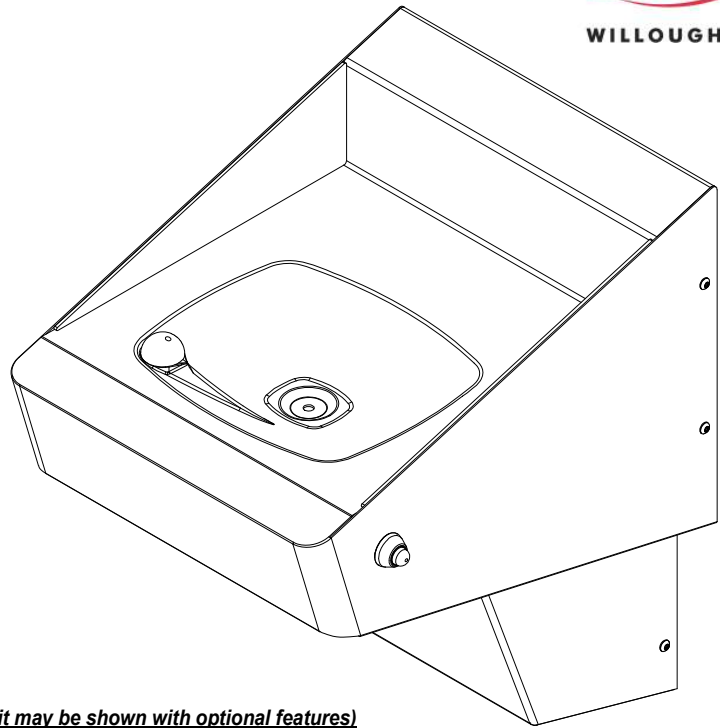

(Unit may be shown with optional features)

To specify fixture and accessories, use the Model Number and Options page.

Example: To specify a Ligature-resistant Front Access Stainless Steel Behavioral Drinking Fountain with ligature-resistant bubbler, single temp. non-metering pneumatic valve, ligature-resistant pneumatic push button, and removable P-trap waste

Use the following Willoughby Model Number:

WBDF-1519-HC-FA-DMBH-PSL1-PBH-RPT

Ligature-resistant Front Access Stainless Steel Behavioral Drinking Fountain shall be:

Willoughby Model No. **WBDF-1519-HC-FA**

(Select from model number and options list on next page)

Wall-hung angular profile fixture shall accommodate one user and is designed to minimize ligature points. Fixture shall be fabricated from 14GA./16GA. Type 304 stainless steel. The construction shall consist of an all-welded lavatory cabinet and all-welded trap enclosure, with exposed stainless surfaces polished to a #4 satin finish.

Standard drinking fountain shall include:

- Shallow bowl, 9" x 10-1/2"
- Stainless steel ligature-resistant bubble
- Slow drain w/ air vent
- Removable P-trap (1-1/2" F.I.P.)
- Angular profile with sloped top
- Removable trap enclosure attached with security screws

Vandal Resistance/Safety Features:

The bubbler, push buttons, and slow drain are non-removable from the user-side and are designed to minimize ligature points. Valve, water supplies, and waste connection are concealed within the trap enclosure. All exposed fasteners shall be vandal-resistant security type screws.

ADA, ANSI, and CBC Compliant:

When the drinking fountain is mounted at the standard adult rim height for fountains, it is designed to comply with all applicable ADA, ANSI (Z124.3 and Z124.6), and CBC (2013, Ch. 11B) accessibility guidelines.

Mounting:

Anchoring shall be from the front with mounting plate with anchoring holes. Unit does not require chase area for installation and maintenance; proper backing and anchoring hardware for drinking fountain mounting provided by others.

visit our website at www.willoughby-ind.com

5105 West 78th Street • Indianapolis, IN. 46268

(317) 875-0830 • Fax: (317) 875-0837 • (800) 428-4065



MADE IN THE U.S.A.

MODEL NUMBER AND OPTIONS:

1.) Base Model Number:

- WBDF-1519-HC-FA Ligature-resistant Front Access Stainless Steel Behavioral Drinking Fountain

2.) Bubblers Selection:

- DMBH Ligature-resistant Deck Mounted Bubbler (Standard)

3.) Valve Selection:

- PSL1 Single Temp. Pneumatic Non-metering (Standard)

4.) Push Button Selection:

- PBH Ligature-resistant Pneumatic Push Button (Standard)

5.) Drinking Fountain Waste:

- RPT Removable P-trap (Standard)

6.) Other Options:

- MT Wall Template
 Other: _____
 Other: _____

Approved For Manufacturing By: _____ Date: _____ Company: _____
 Wall Thickness: _____ Wall Type: _____

VERIFY ALL DIMENSIONS WITH FACTORY PRIOR TO ROUGH-IN
 WILLOUGHBY RESERVES THE RIGHT TO MAKE CHANGES IN DESIGN AND DIMENSIONS WITHOUT FORMAL NOTICE AND WITHOUT INCURRING OBLIGATION.

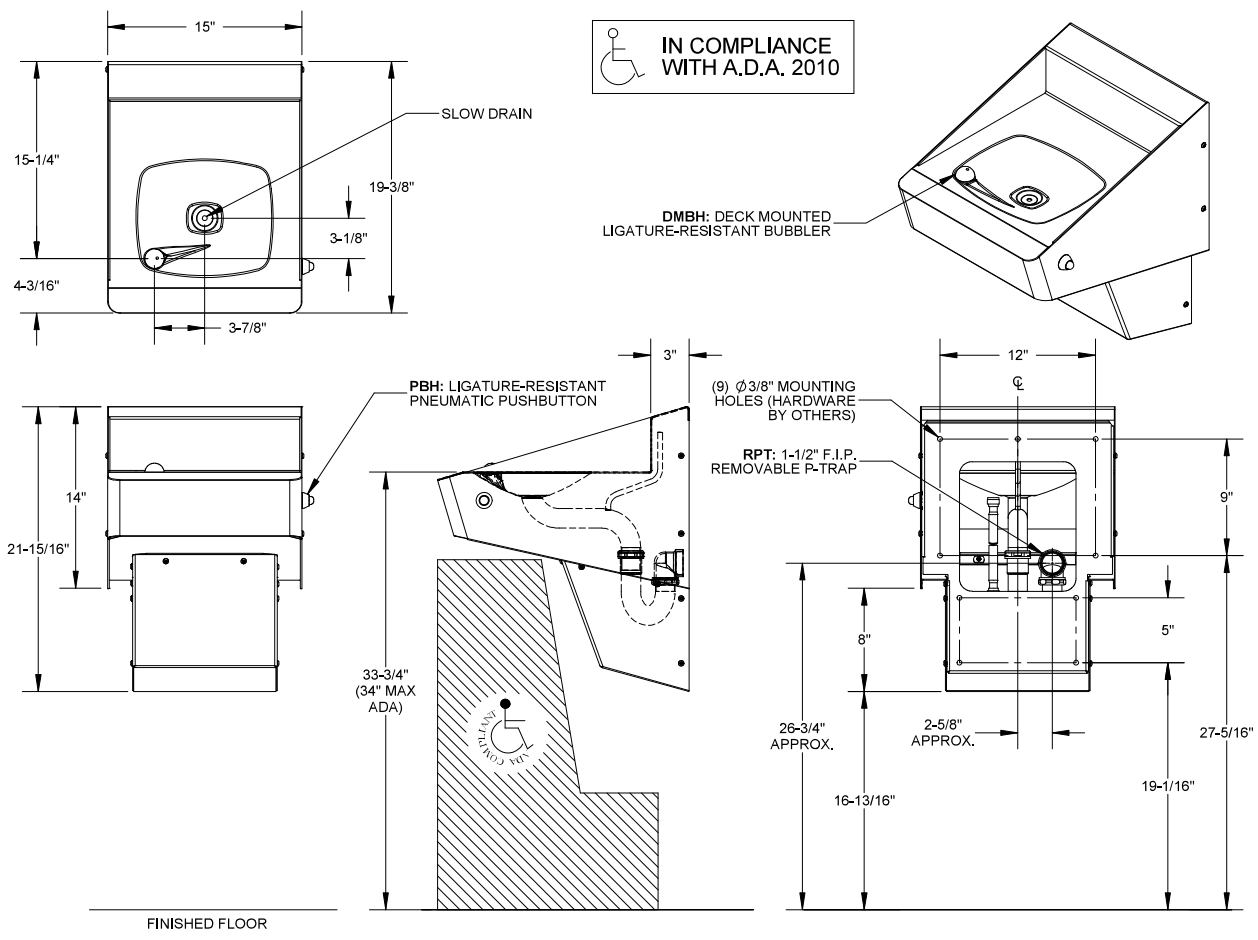

visit our website at www.willoughby-ind.com
 5105 West 78th Street • Indianapolis, IN. 46268
 (317) 875-0830 • Fax: (317) 875-0837 • (800) 428-4065



MADE IN THE U.S.A.