

WBDF-1519-HC Ligature-resistant Rear Mounted Stainless Steel Behavioral Drinking Fountain

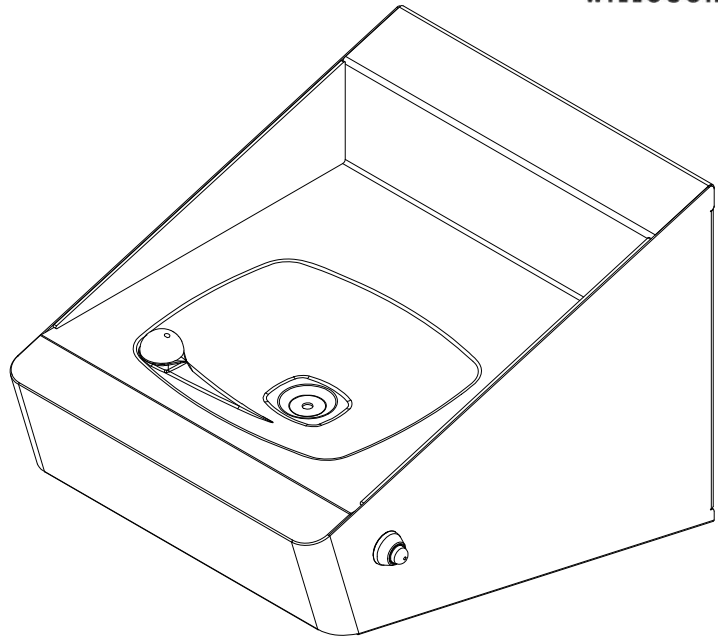

IN COMPLIANCE
WITH A.D.A. 2010

(Unit may be shown with optional features)

To specify fixture and accessories, use the Model Number and Options page.

Example: To specify a Ligature-resistant Rear Mounted Stainless Steel Behavioral Drinking Fountain with ligature-resistant bubbler, single temp. non-metering pneumatic valve, ligature-resistant pneumatic push button, and elbow waste

Use the following Willoughby Model Number:

WBDF-1519-HC-DMBH-PSL1-PBH-EB

Ligature-resistant Rear Mounted Stainless Steel Behavioral Drinking Fountain shall be:

Willoughby Model No. **WBDF-1519-HC**

(Select from model number and options list on next page)

Wall-hung angular profile fixture shall accommodate one user and is designed to minimize ligature points. Fixture shall be fabricated from 14GA./16GA. Type 304 stainless steel.

The construction shall be all welded, with exposed stainless surfaces polished to a #4 satin finish.

Standard drinking fountain shall include:

- Shallow bowl, 9" x 10-1/2"
- Stainless steel ligature-resistant bubbler
- Slow drain with air vent
- Elbow waste (1-1/2" F.I.P.)
- Angular profile with sloped top

Vandal Resistance/Safety Features:

The bubbler, push buttons, and slow drain are non-removable from the user-side and are designed to minimize ligature points. Supply and waste connections are concealed within the lavatory cabinet, with valves and water supplies remotely located in the mechanical chase. The drinking fountain is rear-access and does not have any exposed fasteners.

ADA, ANSI, and CBC Compliant:

When the drinking fountain is mounted at the standard adult rim height for fountains, it is designed to comply with all applicable ADA, ANSI (Z124.3 and Z124.6), and CBC (2013, Ch. 11B) accessibility guidelines.

Mounting:

Anchoring shall be by standard 4-point system: threaded rods, nuts and washers shall be furnished for walls up to 8" thick. Unit shall require chase area for installation and maintenance; proper backing for lavatory mounting provided by others.

visit our website at www.willoughby-ind.com

5105 West 78th Street • Indianapolis, IN. 46268

(317) 875-0830 • Fax: (317) 875-0837 • (800) 428-4065



MADE IN THE U.S.A.

MODEL NUMBER AND OPTIONS:

1.) Base Model Number:

- WBDF-1519-HC Ligature-resistant Rear Mounted Stainless Steel Behavioral Drinking Fountain

2.) Bubblers Selection:

- DMBH Ligature-resistant Deck Mounted Bubbler (Standard)

3.) Valve Selection:

- PSL1 Single Temp. Pneumatic Non-metering (Standard)

4.) Push Button Selection:

- PBH Ligature-resistant Pneumatic Push Button (Standard)

5.) Drinking Fountain Waste:

- EB Elbow Waste (Standard)

6.) Other Options:

- MT Wall Template
 WS Wall Sleeve (Requires Accessible Chase)
 Other: _____
 Other: _____

Approved For Manufacturing By: _____ Date: _____ Company: _____
 Wall Thickness: _____ Wall Type: _____

VERIFY ALL DIMENSIONS WITH FACTORY PRIOR TO ROUGH-IN
 WILLOUGHBY RESERVES THE RIGHT TO MAKE CHANGES IN DESIGN AND DIMENSIONS WITHOUT FORMAL NOTICE AND WITHOUT INCURRING OBLIGATION.

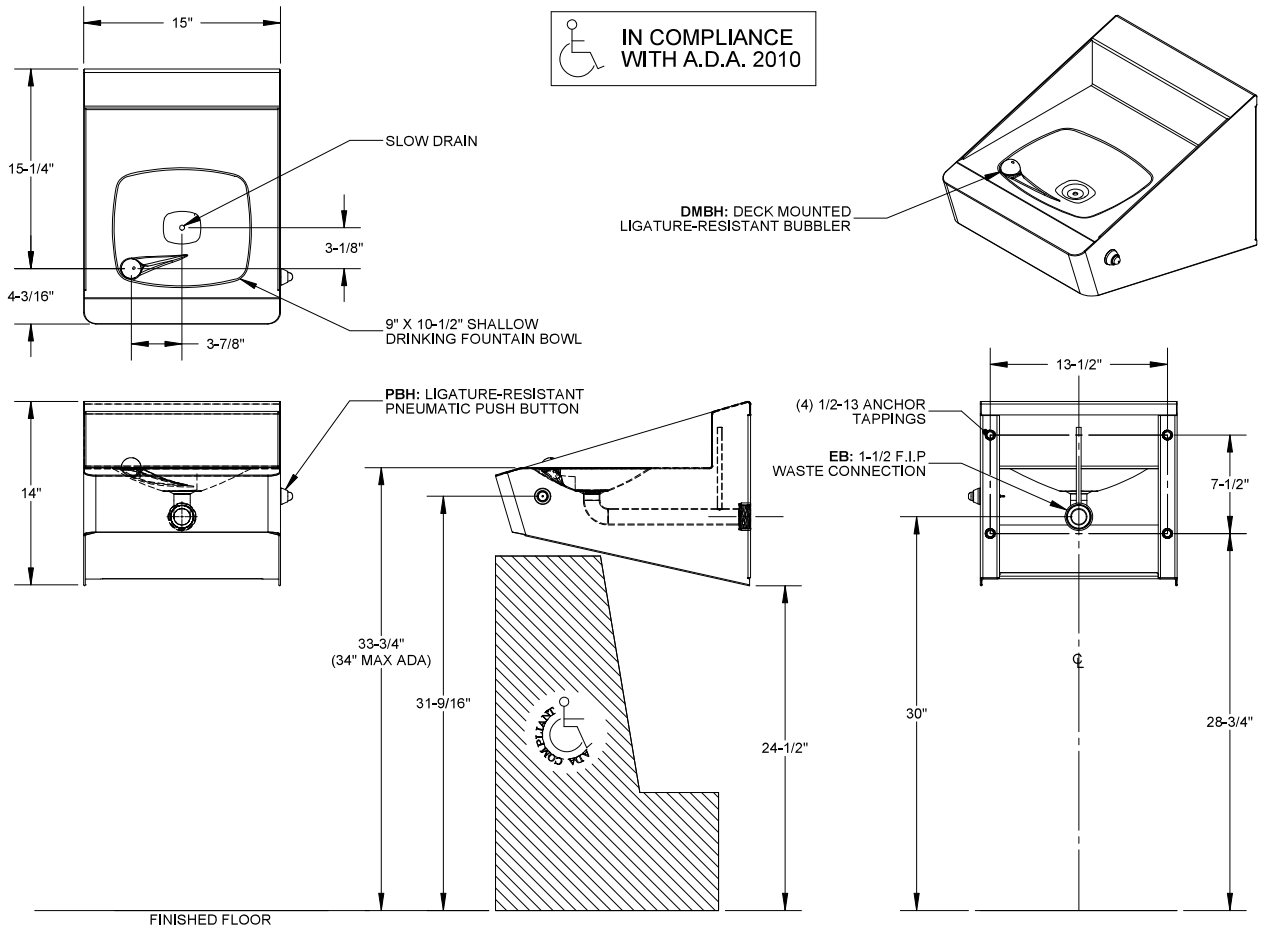

visit our website at www.willoughby-ind.com
 5105 West 78th Street • Indianapolis, IN. 46268
 (317) 875-0830 • Fax: (317) 875-0837 • (800) 428-4065



MADE IN THE U.S.A.