

WSSS-ADA Series ADA-Compliant Surgical Scrub Sink

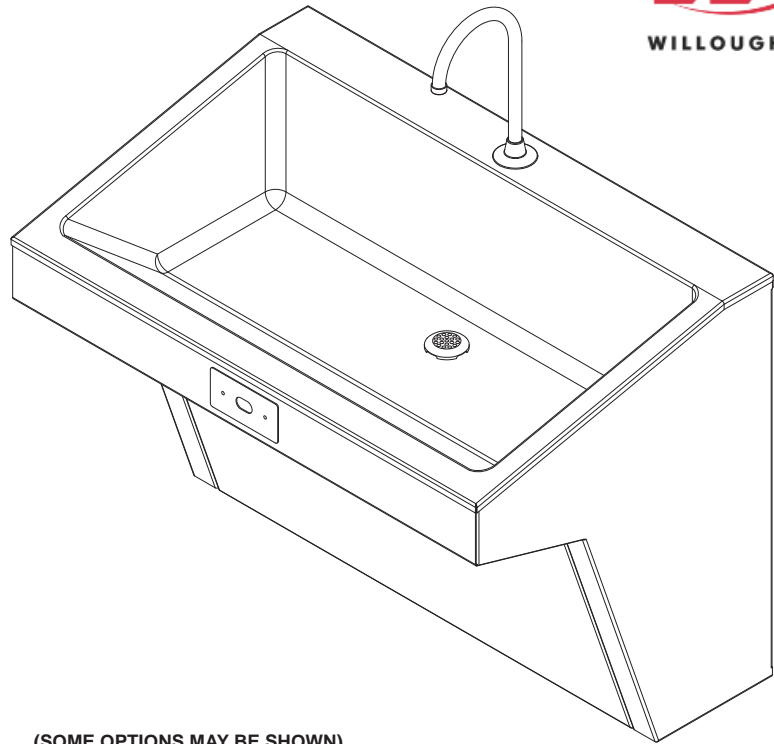

(SOME OPTIONS MAY BE SHOWN)

To specify fixture and accessories, use the Model Number and Options page.

Example: To specify a single station ADA-Compliant Surgical Scrub Sink with standard thermostatic mixing valve, standard infrared sensor actuation, and in-wall mounting carrier

Use the following Willoughby Model Number:

WSSS-ADA-1-TMV-IR-MC

Recommended Specifications

ADA-Compliant Surgical Scrub Sink shall be:
Willoughby Model No. **WSSS-ADA**
(Select from model number and options list on next page)

Fixture shall be fabricated from 16 GA, Type 304 stainless steel. The construction shall be welded with exposed exterior stainless steel surfaces polished to a #4 satin finish. Bowl shall have a bead-blast finish.

Standard equipment shall include:

- Infrared sensor actuated water valves
- Gooseneck faucets with laminar flow nozzles
- Inline thermostatic mixing valves
- Machined stainless steel drain with tailpiece
- 1-1/2" F.I.P. slip joint, cast brass union 'P' trap

Anchoring shall be from the front with 'Z' clip and wall anchoring hardware (by others); a wall mounting carrier or mounting base is available as optional equipment. Unit requires no chase area for installation and maintenance. Two- and Three-stations shall include divider panels.

Units are provided with front panels which are easily removed for access to valves and waste connections.

Optional Features:

- Mounting Carrier

visit our website at www.willoughby-ind.com

5105 West 78th Street • Indianapolis, IN. 46268

(317) 875-0830 • Fax: (317) 875-0837 • (800) 428-4065



MADE IN THE U.S.A.

MODEL NUMBER AND OPTIONS:

1.) Base Model:

WSSS-ADA ADA-Compliant Surgical Scrub Sink

2.) Number of Stations:

- 1 Single Station
- 2 Two Station (with 1 Divider Panel)
- 3 Three Station (with 2 Divider Panels)

3.) Temperature Controls:

TMV Inline Thermostatic Mixing Valves (Standard)

4.) Water Actuators:

IR Infrared Sensor Actuators (Standard)*
 *(Req. 110V power through ground fault interrupter (GFCI) receptacle)

5.) Mounting Options:

- 'Z' Clips (Wall anchors by others) (Standard)
- MC Mounting Carrier (off-floor installation)

6.) Options:

- Other: _____
- Other: _____

Approved For Manufacturing By: _____ Date: _____ Company: _____
 Wall Thickness: _____ Wall Type: _____

VERIFY ALL DIMENSIONS WITH FACTORY PRIOR TO ROUGH-IN
 WILLOUGHBY RESERVES THE RIGHT TO MAKE CHANGES IN DESIGN AND DIMENSIONS WITHOUT FORMAL NOTICE AND WITHOUT INCURRING OBLIGATION.

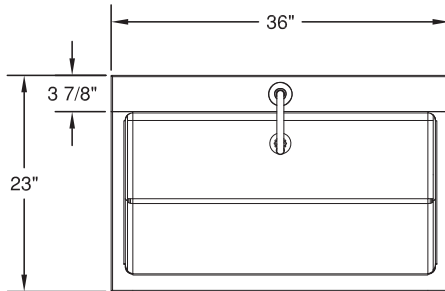

IN COMPLIANCE WITH A.D.A. 2010

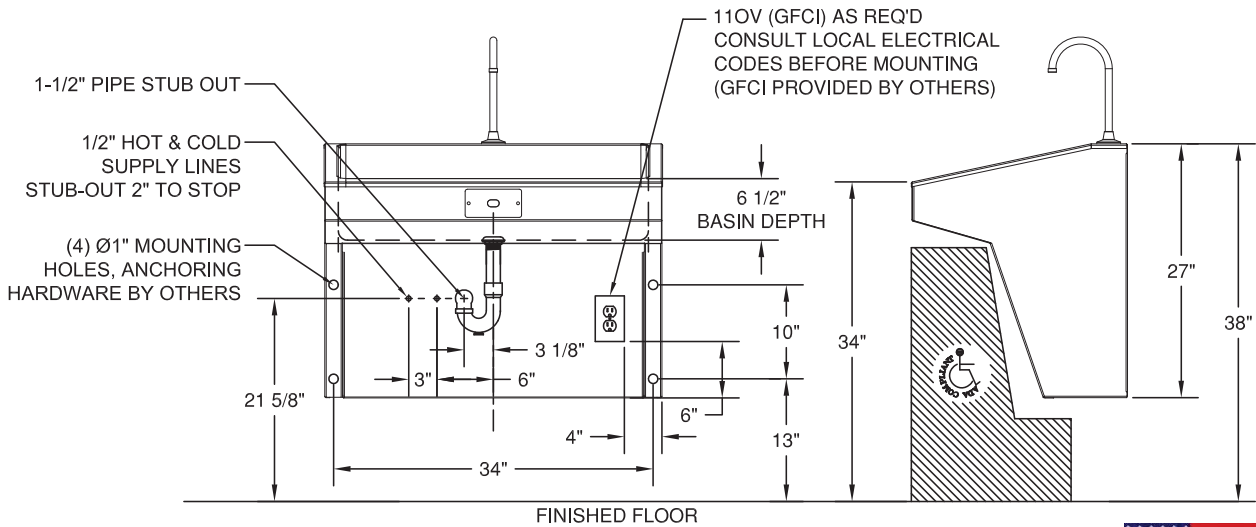

visit our website at www.willoughby-ind.com
 5105 West 78th Street • Indianapolis, IN. 46268
 (317) 875-0830 • Fax: (317) 875-0837 • (800) 428-4065



MADE IN THE U.S.A.