

HBBD Series Hose Box with Wall Flange and Boiler Drain Valve

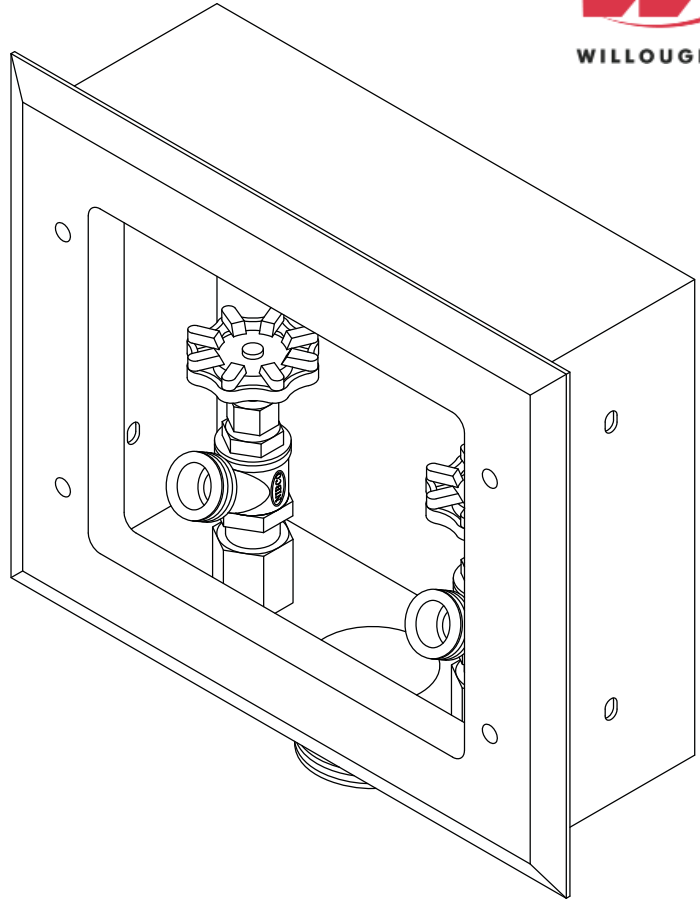

Recommended Specifications

HBBD Series Hose Box with Wall Flange and Boiler Drain Valve shall be: Willoughby Model No. **HBBD-**_____ (Select from model number and options list on next page)

Hose box and wall flange are fabricated from Type 304 stainless steel with exposed surfaces polished to a satin finish. The wall flange shall mount flush to the supporting finished wall.

Standard equipment shall include:

- 1/2" brass boiler drain valve(s)
- 2" M.I.P. drain

The valve and stop feature tamper-resistant lock-shield bonnets and replaceable cartridges containing all wearing parts.

Supply inlets are 1/2" F.I.P. and outlets are 3/4" M.G.H.T.

visit our website at www.willoughby-ind.com

5105 West 78th Street • Indianapolis, IN. 46268
(317) 875-0830 • Fax: (317) 875-0837 • (800) 428-4065



MADE IN THE U.S.A.

MODEL NUMBER AND OPTIONS:

1.) Base Model Number:

- HBBD-8251 Single Temperature HBBD Series Hose Box with Wall Flange and Boiler Drain Valve
- HBBD-8252 Dual Temperature HBBD Series Hose Box with Wall Flange and Boiler Drain Valve

2.) Other Options:

- Other _____
- Other _____

Approved For Manufacturing By: _____ Date: _____ Company: _____
 Wall Thickness: _____ Wall Type: _____

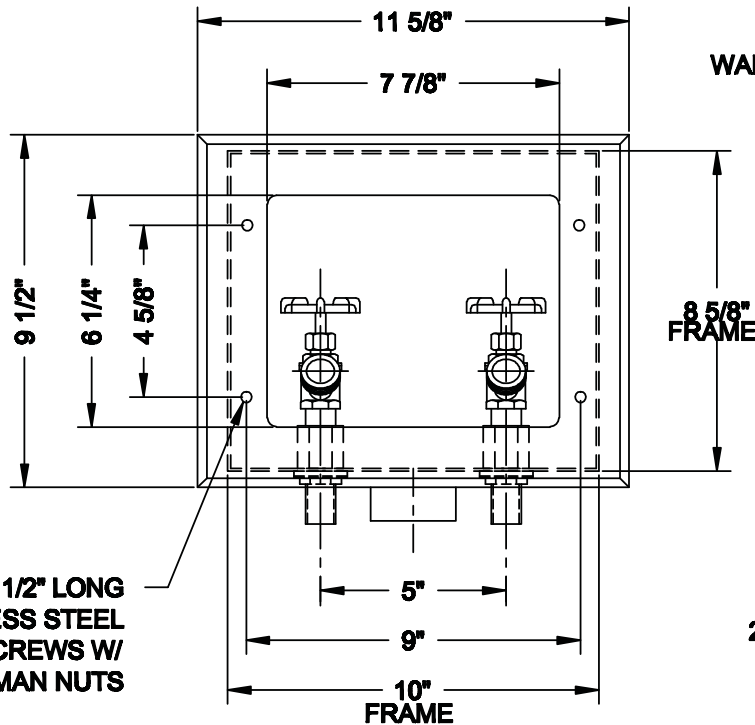
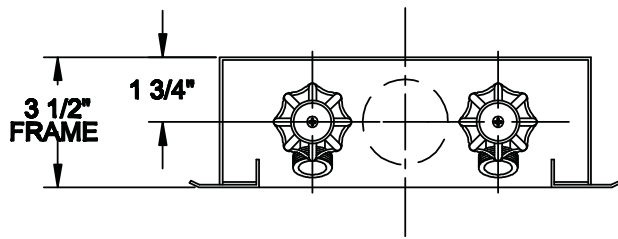

**(2) 1/4" x 3/8" LONG
WALL MOUNTING SLOTS
EACH SIDE**

**(2) NIBCO
HOSE BIBBS**

2" M.P.T. DRAIN

**(4) 1/4"-20 x 1/2" LONG
STAINLESS STEEL
SECURITY SCREWS W/
TINNERMAN NUTS**

VERIFY ALL DIMENSIONS WITH FACTORY PRIOR TO ROUGH-IN
 WILLOUGHBY RESERVES THE RIGHT TO MAKE CHANGES IN DESIGN AND DIMENSIONS WITHOUT FORMAL NOTICE AND WITHOUT INCURRING OBLIGATION.

visit our website at www.willoughby-ind.com
 5105 West 78th Street • Indianapolis, IN. 46268
 (317) 875-0830 • Fax: (317) 875-0837 • (800) 428-4065



MADE IN THE U.S.A.