

# Installation & Operation Manual

## WAF-3606 Series

### AquaFount® 36" 360° Solid Surface Washfountain Electronic/Pneumatic

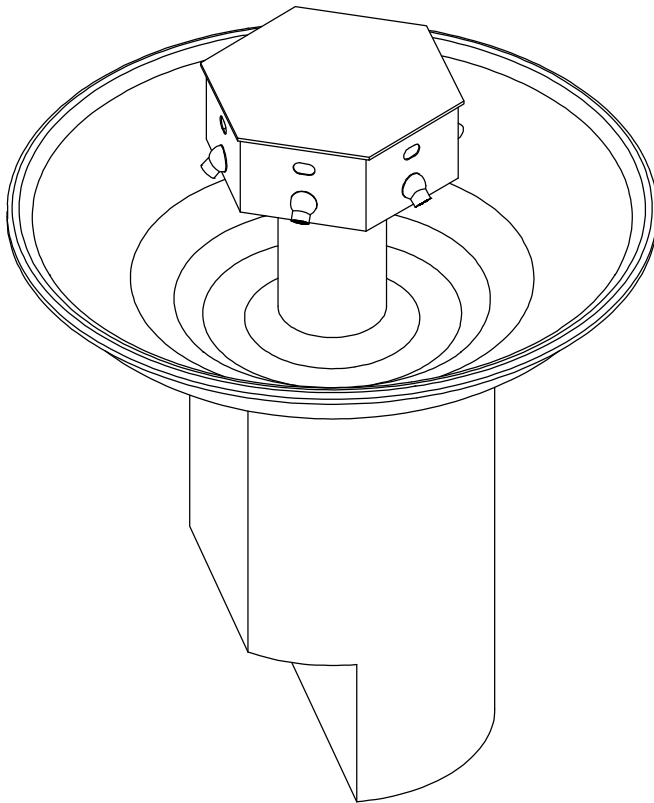

**WAF-3606**



#### Table of Contents

Pre-Installation Information.....	3
Physical / Rough-in Dimensions.....	4
Required Installation Supplies.....	5
Parts List.....	6
Exploded-view Drawing.....	7
Hardware Identification.....	8
Installation Instructions.....	
Step 1: Pedestal Mounting.....	9
Step 2: Head and Basin Assembly.....	10
Step 3: Drain Assembly.....	11
Step 4A: Connections for Infrared/Piezo Actuators.....	12
Step 4B: Connections for Pneumatic Actuators .....	13
Step 5: Final Assembly.....	14
JACO Fitting Instruction.....	15
Adjustable Mixing Valve Installation.....	16
Infrared Sensor Installation Instructions.....	17
Pneumatic Valve Operation Details.....	18
Liquid Soap Specification and Maintenance.....	19
Care and Maintenance.....	20
Troubleshooting.....	
Infrared Sensors.....	21
Electronic Valves.....	22
Pneumatic Valves.....	23
Drawings.....	
General Dimensions and Rough-in Detail.....	25
Valve Details.....	26
Miscellaneous Details.....	30
Warranty.....	34



**Willoughby Industries, Inc.**

5105 West 78th Street  
Indianapolis, IN 46268  
Toll Free: (800) 428-4065  
Local: (317) 875-0830  
Fax: (317) 875-0837  
www.willoughby-ind.com

**WILLOUGHBY**

Rev. 10/2016

MADE IN THE U.S.A.



***(Page intentionally left blank)***

## Pre-Installation Information

# Installation notice!

Check Rough-In location **PRIOR** to installation

Flush lines thoroughly **PRIOR** to hook-up

When installing the **Willoughby Industries' WAF-3606 Series** washfountain system:

Before Step 1 of the installation instructions, ensure that rough-ins are in the correct location.

The valve assembly, including the spray head, **MUST NOT BE** connected until *after* all lines have been flushed to remove the small particles of debris that are inherent with new construction projects and all chemicals that are used in flushing are purged from the system.

Chemicals used in flushing plumbing systems can attack the internal components of the valve and spray head and severely damage them, so any flushing of the system must be followed by a full flushing with pure water to clear any harsh chemicals remaining in the system. Debris in the system if allowed to enter the valve assembly and spray head can cause poor performance or outright failure.

Again **DO NOT** attempt to connect the valve assembly and spray head until *after* all flushing is complete and pure water is the only media that will be passing through the system. Damage to the valve assembly or spray head caused by harsh chemicals or debris will not be covered by the manufacturer's warranty.

# Installation notice!

Check Rough-In location **PRIOR** to installation

Flush lines thoroughly **PRIOR** to hook-up

# Physical / Rough-in Dimensions- WAF-3606

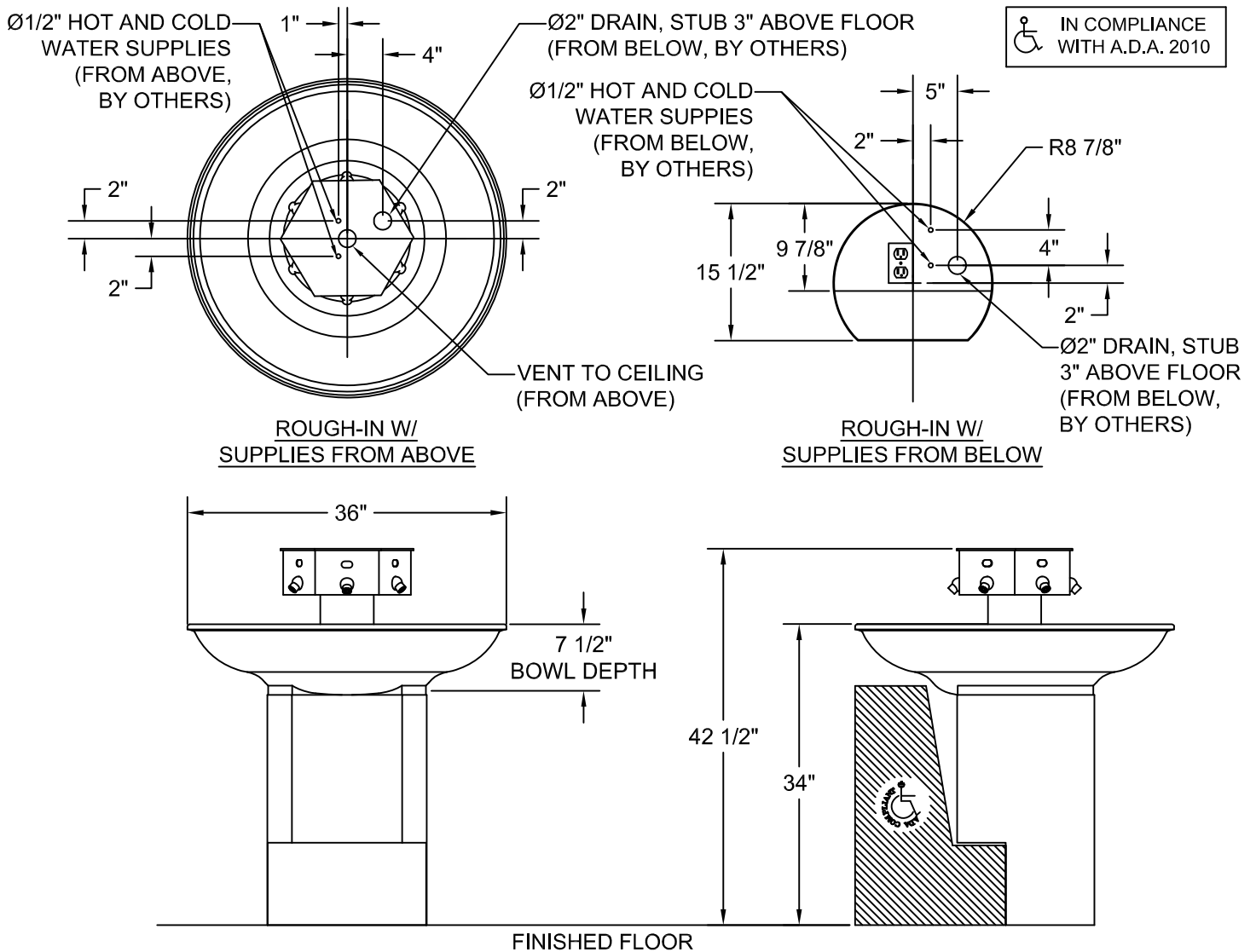

## **Required Installation Supplies**

- Proper mounting hardware
- Hardware for waste outlet connections
- Gasket for waste outlet connection
- Shims (for installation if necessary)
- Supply piping
- Silicone caulk
- Plumbers putty

**□ WARNING: Willoughby Industries does not assume any responsibility for personal injury or damage to equipment due to an improperly installed WAF-3606 Series washfountain.**

# **Parts List**

ITEM #	DESCRIPTION	PART NUMBER (P/N) - 6-STATION
1	36" FULL-ROUND BASIN - SOLID SURFACE	803606C-XX*
2	TOP COVER - SOLID SURFACE	802020-XX*
3	DRAIN ASSEMBLY (WAF)	380281
4	ACTUATOR HOUSING / VALVE HEAD KIT - INFRARED	813600-6I
	ACTUATOR HOUSING / VALVE HEAD KIT - PIEZO	813600-6E
	ACTUATOR HOUSING / VALVE HEAD KIT - PNEUMATIC	813600-6P
5	ELECTRONIC VALVE ASSEMBLY	803105-6EW
	PNEUMATIC VALVE ASSEMBLY	803105-6PW
6	PEDESTAL (FLOOR-MOUNT)	800108T-3FL
7	ACCESS PANEL	S600229
<b>NOT SHOWN</b>	STND. SPRAY HEAD ASSEMBLY- WAF (AERATOR SPRAY HEAD, 0.5 GPM- #320157A) (SPRAY HEAD BASE, 45*- #800001)	320157A-ASMB
	HARDWARE KIT	800258
	INFRARED SENSOR	700150
	PIEZO PUSHBUTTON	701179-C
	ACTUATOR PUSHBUTTON	600307
	CHECKSTOP ASSEMBLY	980183
	STAINLESS STEEL FLEX HOSE (6")	980506
	STAINLESS STEEL FLEX HOSE (20")	980520
	POWERS HYDROGUARD T/P (LFe480)	700480ELF
	LIQUID SOAP SYSTEM	LSD6B
	POWER SUPPLY	800137B

\*XX REPRESENTS THE WASH FOUNTAIN COLOR

- WHITE GRANITE=WG
- SAND STONE=SS
- GRAY GRANITE=GG
- BLACK GRANITE=BG
- SEA GREEN=SG
- NOCTURNAL BLUE=NB
- RED CORAL=RC
- GLACIER WHITE=GW
- BONE=B

# Exploded-view Drawing

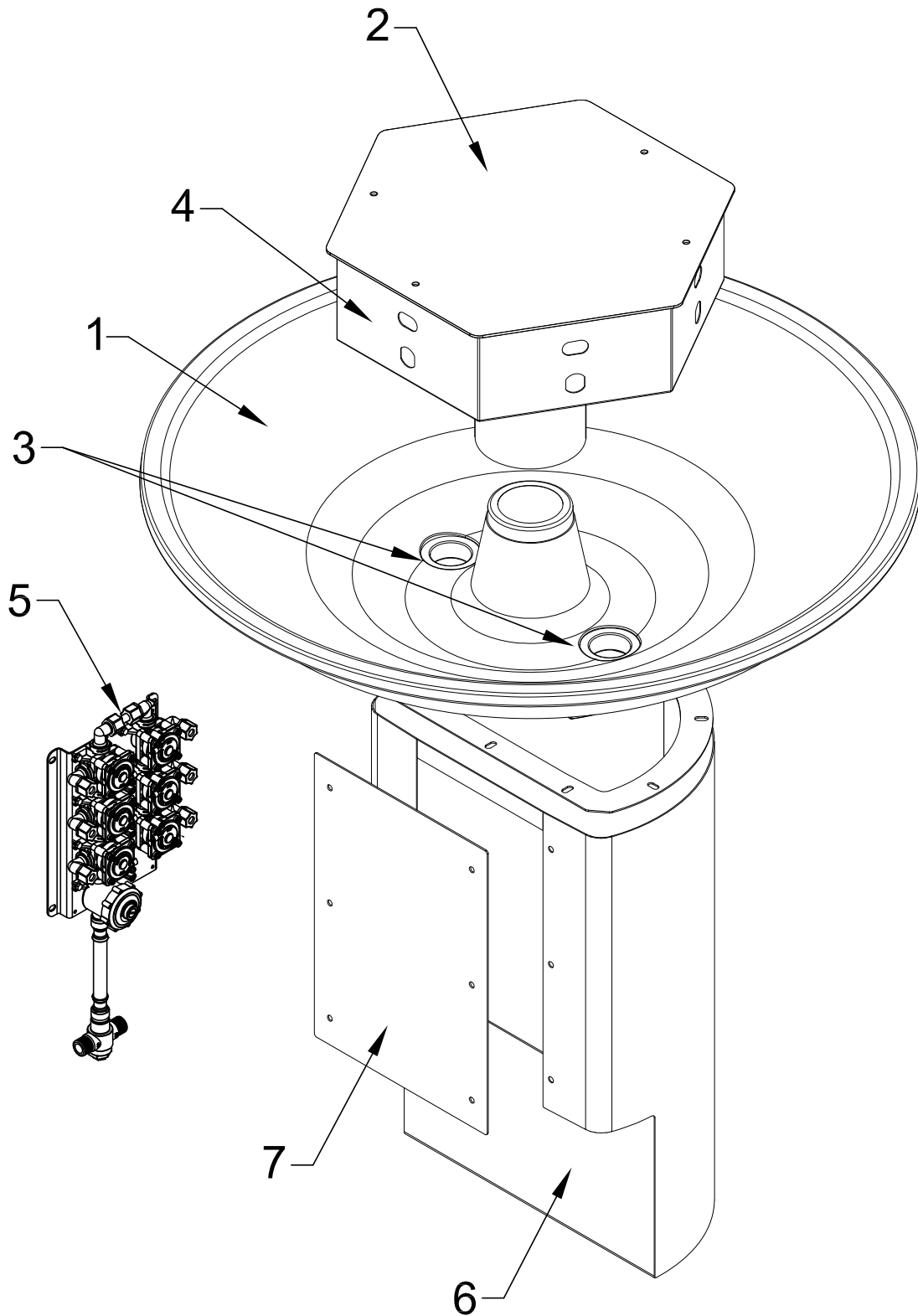

# Hardware Identification

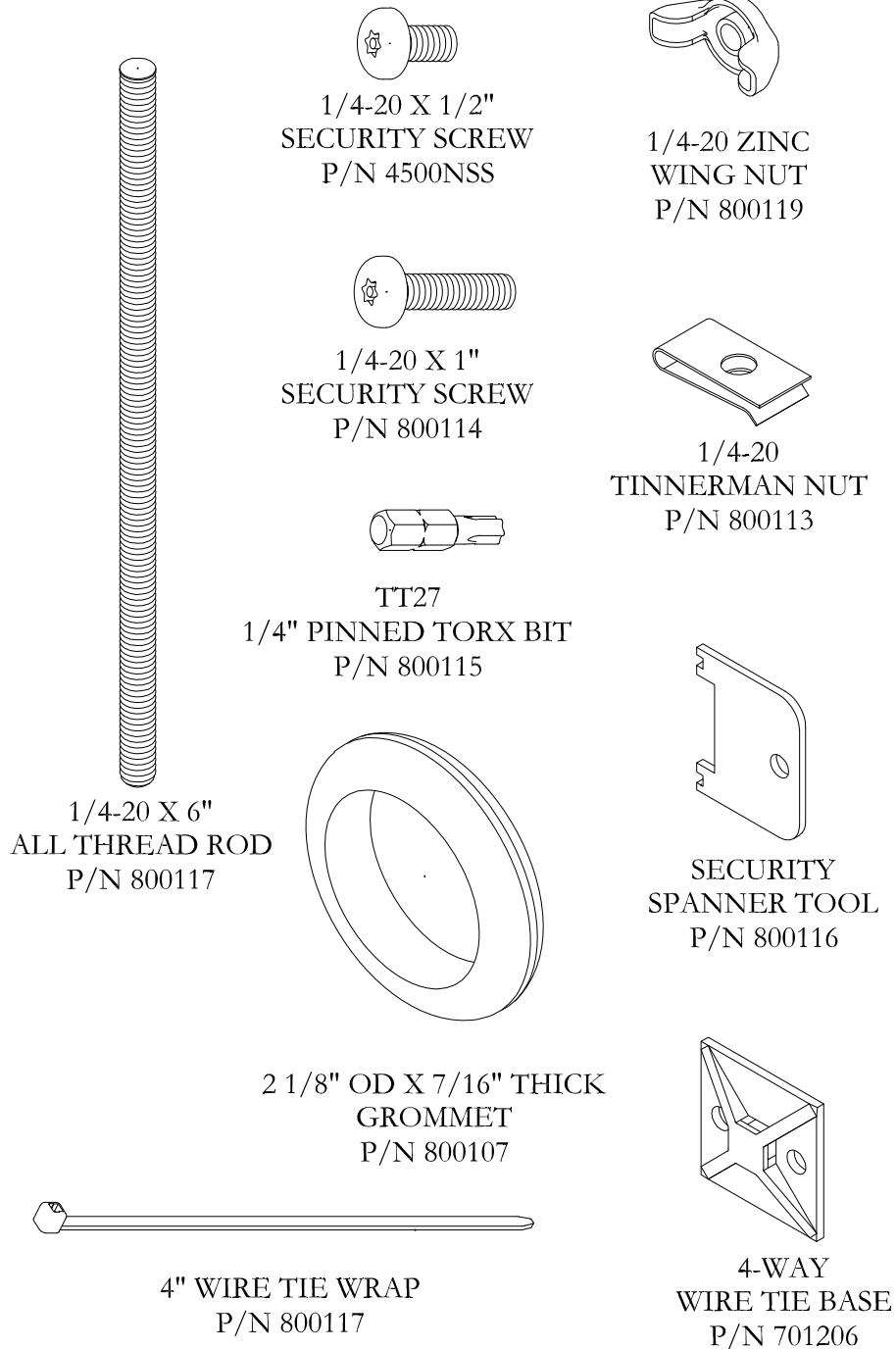



# **Installation Instructions**

## **Step 1: Pedestal Mounting**

### **Parts supplied:**

- Pedestal base assembly

***Note: Hardware for floor anchoring by others***

- 1.) Unpack pedestal and inspect parts.
- 2.) Place pedestal at the desired position and mark anchor holes (anchors by others). *Make sure that the intended anchor locations will provide adequate backing to support the installed washfountain. If adequate backing does not exist, install appropriate support backing or relocate unit before proceeding with installation* (backing provided by others).
- 3.) Secure the pedestal to the floor using anchors that are adequate for the type of floor.

## Installation Instructions (cont.)

### Step 2: Valving and Basin Assembly

#### Parts supplied:

- Washfountain wash basin
- Pedestal base assembly
- Actuator housing assembly
- 1/4"-20 X 1/2" security screws

**Caution:** Do not leave bowl on the pedestal unsupported, as it may fall and cause damage or personal injury.

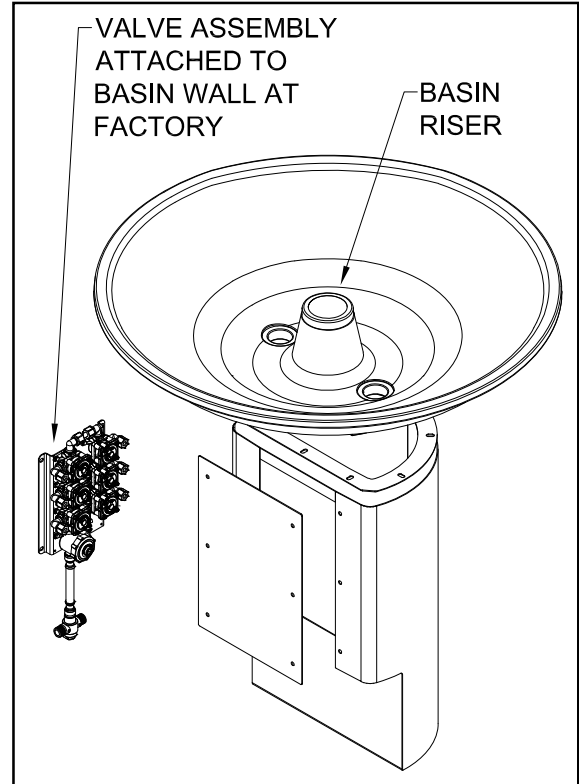

- 1.) With the help of an assistant, place the basin on top of the pedestal aligning the threaded inserts in the bottom with the holes in the top support ring. Secure with security screws.

**Note:** BE SURE to use the security screws included with the washfountain. Using longer screws than those provided can damage the solid surface basin.

- 2.) Place the head assembly over the center of the basin riser aligning the holes with threaded inserts. Secure with security screws, but DO NOT OVERTIGHTEN; this can damage the solid surface basin and actuator housing.
- 3.) The wash basin is ready for plumbing installation.

## Installation Instructions (cont.)

### Step 3: Drain Assembly

#### Parts/Materials supplied:

- Solid surface basin
- Drain assembly (see diagram)
- Plumbers putty (supplied by others)

- 1.) As shown on the diagram, apply a small (approx. 1/4" dia. 6" long) strand of plumbers putty on the underside of the drain basket lip (putty supplied by others).
- 2.) Insert the drain basket down through the basin drain hole.
- 3.) Secure the drain basket in place by fitting the rubber and stainless steel washers onto the drain assembly from the underside of the basin. Tighten the locknut onto the drain basket assembly, sandwiching the washers between the basin and locknut.

**Note: Over-tightening the locknut or security screw can damage the solid surface basin and/or drain assembly components.**

- 4.) Secure the drain cover to the drain basket using the provided screw.

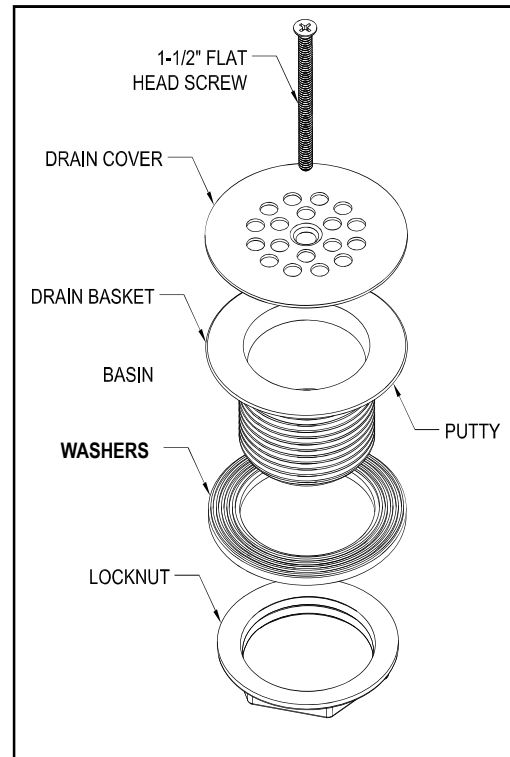

## Installation Instructions (cont.)

### Step 4A: Connections for Infrared/Piezo Actuators

#### Parts supplied:

- Valve Assembly (pre-installed)
- 3/8" x 4' Multi-Colored Water Lines
- Small Diameter Multi-Colored Pneumatic Tubing
- 1/4-20 x 1/2" security screws
- 1/4-20 tinnerman nuts

**Note: Use wire tie mounts and wire ties to route and secure wiring. Wires are long enough to accommodate various routing paths. Longer tubes may need to be bundled with wire ties so they do not come in contact with sharp corners.**

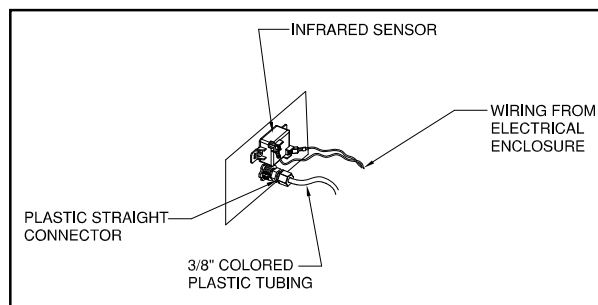

**Infrared Sensor Actuator**

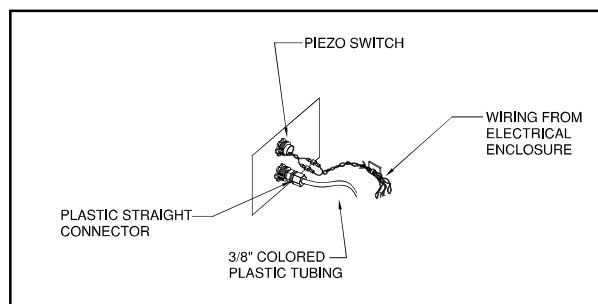

**Piezo Push Button Actuator**

- 1.) Locate the terminal block plate and attach to the pedestal using 1/4-20 x 1/2" security screws and tinnerman nuts.
- 2.) Locate the group of loose colored wires coming from the terminal block plate labeled "UPPER".
- 3.) Feed 2 like-colored wires into each of the actuator housing assemblies (either the Infrared or Piezo assemblies, whichever applies to the installation).
- 4.) Plug both like-colored wires into the actuator as shown above (either wire will work on each connector).
- 5.) Locate the 3/8" multi-colored water lines. Match the color of each water line with the corresponding color of wiring. Run the end of each water line up through the basin to the head kit. Match the color of each water line to the spray head assembly below each actuator. On each corresponding spray head, loosen the plastic nut on the plastic connector and firmly push the water line through the plastic nut into the fitting. Tighten the plastic nut to secure the water line to the spray head. Repeat for each remaining water line. (\*\*see JACO Fitting Instructions on Page 15 for further detail).
- 6.) Once all water lines have been attached to their corresponding spray heads, on each corresponding manifolded valve assembly, loosen the plastic nut on the plastic connector and firmly push the water line through the plastic nut into the fitting. Tighten plastic nut to secure the water line to the valve assembly. Repeat for each water line.
- 7.) Connect each set of like-colored wires to each of the manifolded valves.

## Installation Instructions (cont.)

### Step 4B: Connections for Pneumatic Actuators

#### Parts supplied:

- Valve Assembly (pre-installed)
- 3/8" x 4' Multi-Colored Water Lines
- Small Diameter Multi-Colored Pneumatic Tubing
- 1/4-20 x 1/2" security screws
- 1/4-20 tinnerman nuts

**Note: Use wire tie mounts and wire ties to route and secure tubing. Longer tubes may need to be bundled with wire ties so they do not come in contact with sharp corners.**

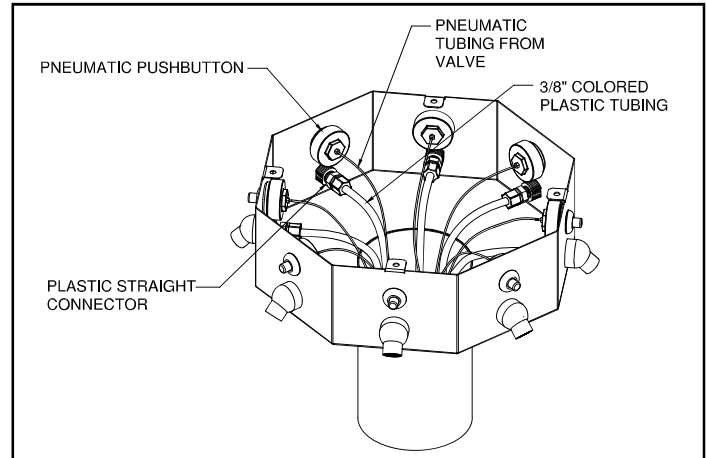

**Pneumatic Push Button  
(Similar 8-station head kit shown)**

- 1.) Locate the small multi-colored pneumatic tubing. Feed each one into each of the actuator housing assemblies.
- 2.) Plug each tube onto the hose barb on the back of the push button.
- 3.) Locate the 3/8" multi-colored water lines. Match the color of each water line with the corresponding color of tubing. Run the end of each water line up through the basin to the head kit. Match the color of each water line to the spray head assembly below each push button actuator. On each corresponding spray head, loosen the plastic nut on the plastic connector and firmly push the water line through the plastic nut into the fitting. Tighten the plastic nut to secure the water line to the spray head. Repeat for each remaining water line. (\*\*see JACO Fitting Instructions on Page 15 for further detail).
- 4.) Once all water lines have been attached to their corresponding spray heads, on each corresponding manifolded valve assembly, loosen the plastic nut on the plastic connector and firmly push the water line through the plastic nut into the fitting. Tighten plastic nut to secure the water line to the valve assembly. Repeat for each water line.
- 5.) Connect each set of like-colored tubing to each of manifolded valves.

## Installation Instructions (cont.)

### Step 5: Final Assembly

#### Parts supplied:

- Solid surface cover
- Front panel
- Spacer tray
- 1/4"-20 tinnerman nuts
- 1/4"-20 X 1" security screws
- 1/4"-20 X1" flat head security screws
- 1/4"-20 hex couplings

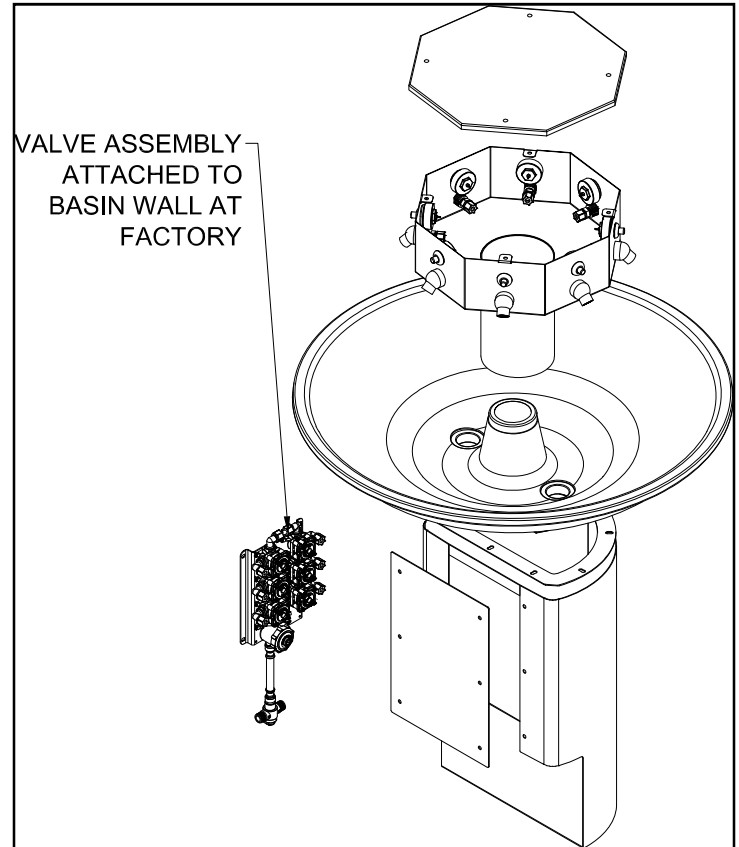

(Silimar 8-station unit shown)

- 1.) Make all final plumbing connections to valve inlets using supplied flex hoses (flex hoses have shut-off valves attached that should be connected to the supply inlets).
- 2.) Once all of the connections in the actuator housings are complete, locate the transformer.

**NOTE: PLUG-IN TRANSFORMER (IF NEEDED) MUST BE USED WITH A GROUND FAULT INTERRUPT (GFCI) RECEPTACLE TO HELP PREVENT POSSIBLE ELECTRICAL SHOCK.**

- 3.) Make final adjustments to valves and replace solid surface top cover and the two pedestal access covers with security screws.

# JACO Fitting Instruction



*Note: It is not necessary to disassemble this fitting for application. Merely insert tubing to stop and tighten seal.*

1. Cut tubing end squarely and remove the internal burrs.
2. Insert the tubing through the back of the nut all the way through the nut assembly to the tube stop in the fitting body (see illustration). If the tubing does not enter the nut easily, loosen the nut one turn and reinsert the tubing all the way to the tube stop in the fitting body.
3. Turn the nut hand tight.
4. Wrench tighten the nut  $1\frac{1}{2}$  - 2 turns.
5. All nuts must be retightened when the system reaches projected operating temperature.

*Note: To ensure proper assembly, tubing MUST be fully inserted into the fitting body all the way to the tube stop.*

*Note: Squeaking sound when tightening nut is normal. For pipe threaded connections, Teflon tape must be used.*

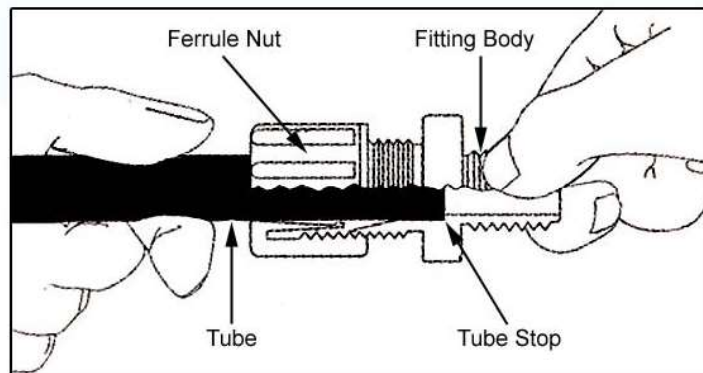
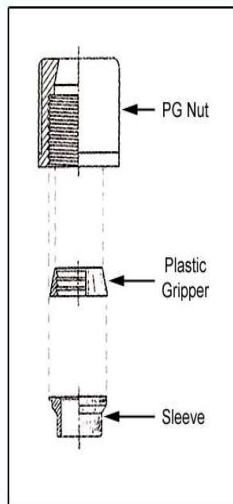

# Adjustable Mixing Valve Installation

**POWERS™**

IS-P-e480

**HydroGuard® T/P Series e480  
Lavatory Combination Valve**

## Installation Instructions

### To Install ■

**NOTE:** Installation should be in accordance with accepted plumbing practices. Flush all piping thoroughly before installation.

1. Locate a suitable place for the tempering valve. Valve should be accessible for service and adjustment and as close to the point-of-use as possible.
2. Connect hot and cold water to the supply valve using 1/2" NPT or 3/8" compression connections.
3. Connect outlet of tempering valve to fixture(s) using 1/2" NPT or 3/8" compression connections.
4. Turn on hot and cold water supplies. If any leaks are observed, tighten connections as necessary to stop leaks before proceeding.
5. Turn on fixture and allow water to flow for 2 minutes. Measure water temperature at outlet. If water is not at desired temperature, adjust as necessary.

### Specifications ■

e480-00 .....	1/2" NPT (Rough Bronze)
e480-01 .....	1/2" NPT (Rough Chrome)
e480-10 .....	3/8" Compression (Rough Bronze)
e480-11 .....	3/8" Compression (Rough Chrome)
Capacity: .....	4.0 gpm (15.0 l/m)
Approach Temperature: .....	5°F (2.8°C) above set pt.
Max. Operating Pressure: .....	125psi (862 kpa)
Max. Static Pressure: .....	125psi (862 kpa)
Max. Hot Water Temperature: .....	180°F (82°C)
Temp. Adjustment Range:	
..... ASSE Type T/P: 95 – 110°F (43-48°C)	
..... ASSE Type T: 80 – 120°F (27-49°C)	
Minimum Flow: .....	0.5 gpm (2.2 l/m)
Checks: .....	Integral
Construction: .....	Cast Brass Body
Certified: .....	CSA B125
Listing .....	ASSE 1016-1996 (Type T/P)
.....	ASSE 1070

#### CALIFORNIA PROPOSITION 65 WARNING

**WARNING:** This product contains chemicals known to the State of California to cause cancer and birth defects or other reproductive harm. (California law requires this warning to be given to customers in the State of California.)  
For more information: [www.watts.com/prop65](http://www.watts.com/prop65)

Figure 1

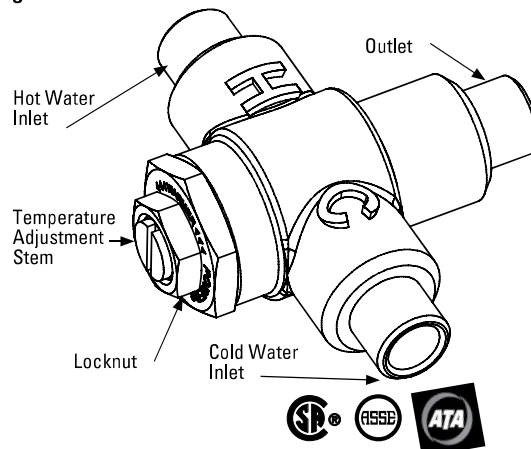
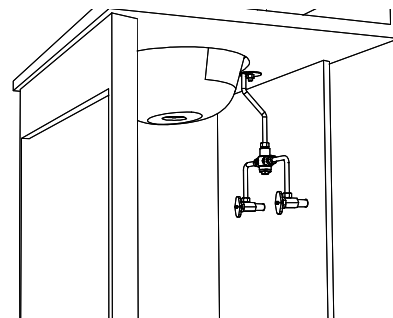

Figure 2: Typical Installation



### To Adjust Temperature ■

1. Loosen locknut.
2. Turn on fixture and run water for at least two (2) minutes to allow supply temperature to stabilize.
3. Turn temperature stem counter-clockwise for hotter or clockwise for colder outlet temperature.
4. Tighten locknut to prevent accidental or unauthorized temperature adjustment.
5. Re-check outlet temperature.

### Repair Kit ■

Motor Repair Kit..... 480-270



# Infrared Sensor Installation Instructions

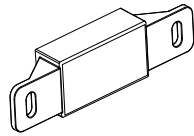

## Willoughby Industries Infrared Lavatory Sensor Installation Instructions

### DETECTION AND ACTIVATION

When the sensor detects a user, a slow flashing red light appears in the sensor window. After 1 to 2 seconds of detection, the light flashes rapidly and the sensor immediately activates the solenoid valve to begin water flow. The solenoid valve remains open as long as the user is detected. The solenoid valve turns off when the user is no longer detected. The sensor is set to activate the solenoid for a maximum of 30 seconds before automatically shutting off.

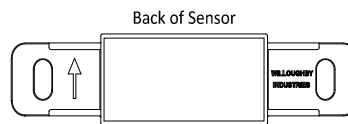

Figure 1

### INSTALLATION AND REPLACEMENT

1. Disconnect 24Vac power at the transformer or fuse box.
2. Remove top cover to expose sensors.
3. Install new sensor. Make sure sensor arrow is pointing up. See figure 1.
4. Connect the red male power cable to the red female connector on the sensor. See figure 2.
5. Connect the black female solenoid cable to the black male connector on the sensor. See figure 2.
6. Replace top cover removed in step 2.
7. Reconnect power.

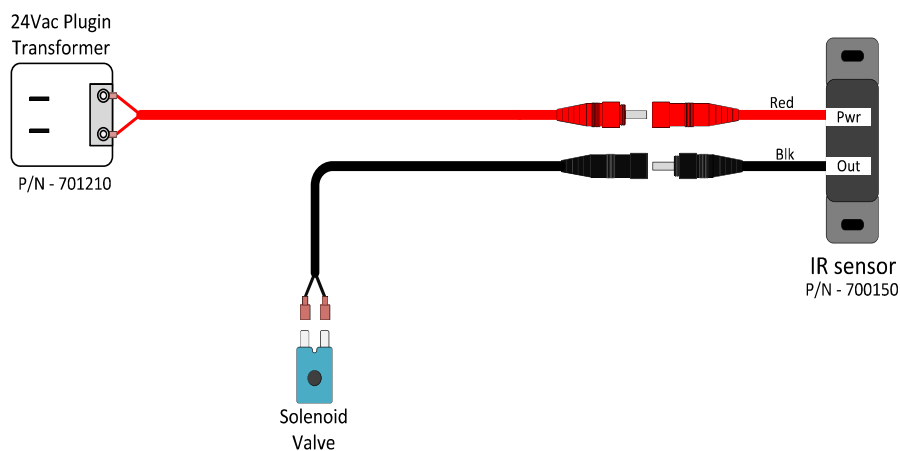
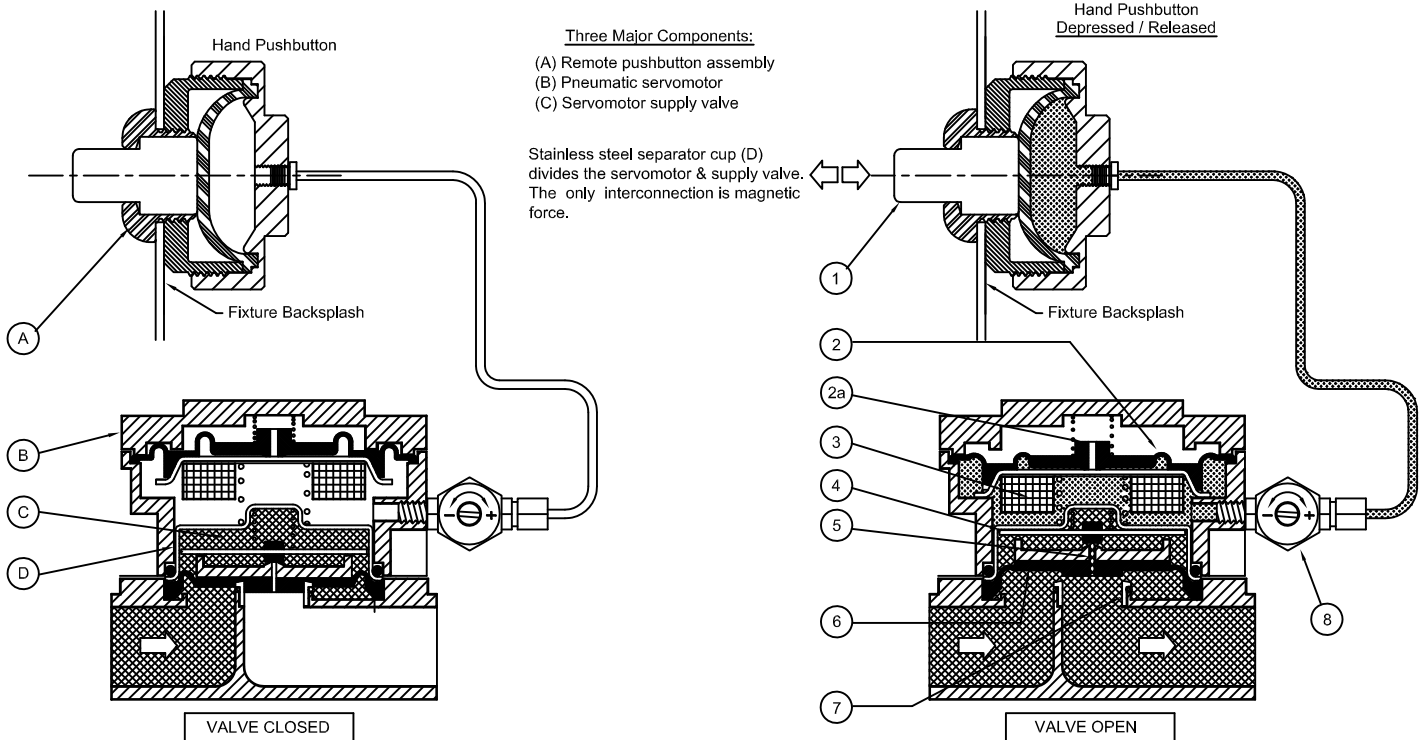

Figure 2

# Pneumatic Valve Operation Details



**Valve Closes:** Air bleeds in through the timer (8) into the chamber below the actuating diaphragm (2). When the pressure in this chamber returns to normal, the diaphragm (2), and the magnet (3), are forced up. The pilot orifice plate (4) drops, covering the pilot orifice (5). Water pressure increases above the seat diaphragm (6), closing the diaphragm (6), against the seat (7).

**Valve Opens:** Depressing the button (1), forces air through the actuating diaphragm check valve (2a), and to atmosphere. Releasing the button (1), creates a vacuum below actuating diaphragm (2), and magnet (3). Diaphragm (2), and magnet (3), are forced down. Pilot orifice plate (4) is pulled up by magnet (3), opening the pilot orifice (5), bleeding off line pressure from above the seat diaphragm (6). Water pressure then lifts the seat diaphragm (6), off the seat (7), and opens the valve.

---

# **Liquid Soap Specification and Maintenance**

(For models with “LSD” option only)

Liquid soap viscosity is measured in “cps” (centipoise). The liquid soap chosen to be used with Willoughby’s Liquid Soap Dispenser should be between 100cp and 2500cp.

The viscosity of the soap should be thin and free flowing.

Some soap types are available in a concentrate and must be diluted with water.

The pH (acidity) level should be in the range of 6.5 to 8.5.

Soap which is too acidic (pH less than 6.5) can corrode stainless steel and degrade rubber, plastic, or chrome-plated materials.

Soap that is outside the range of 6.5 - 8.5 might be harsh on the hands or skin.

(Generally, any quality soap meeting the viscosity and pH guidelines should work well.)

## **Recommended Maintenance Schedule**

To maintain proper function, Willoughby’s Liquid Soap Dispenser should be cleaned periodically to remove soap residue. The Liquid Soap Spout should be soaked in hot water for a period of 30 minutes when cleaning is being performed. The soap tray should also be cleaned with hot water.

## **Care and Maintenance**

### **Solid Surface Care**

Surfaces may be easily cleaned using conventional cleaning agents such as an ammonia based liquid cleaner, (glass cleaner).

Dry stains on a matte finish can be removed with a 3M Scotch-Brite gray scouring pad or a mild abrasive cleaner.

Burns or scorches can be removed by sanding with coarse grit sandpaper followed by finer grit (220) sandpaper. Follow sanding with a 3M Scotch-Brite gray pad (or equivalent) to match finish of sanding area to surrounding area. A final buffing may be required on polished surfaces. Accidental nicks or chips can be repaired with special patch kits available in all colors.

Avoid exposing surfaces to strong chemicals such as acetone's; paint removers and sulfuric acid or hydrochloric chemical cleaners. Exposure to strong chemicals may result in permanent damage to surfaces.

---

### **Stainless Steel Care**

Stainless Steels are basically alloys of iron and chromium and are corrosion resistant. Stainless steel has a bright surface that is easy to clean and is free from oxides. Therefore, cleaning of stainless steel is relatively simple and easy if done on a regular basis.

Frequency of cleaning should depend on the rate at which the fixture becomes dirty. Remember that fresh (soft) deposits of all kinds are relatively easy to remove, while removing older (hard) deposits are much more difficult. Establish a cleaning SCHEDULE.

Routine cleaning should involve ordinary soap or detergent and water, applied with a sponge, brush or cloth. Baking soda, borax or any of several non-abrasive commercial cleansing agents can help hasten the cleaning action. after scrubbing, rinse THOROUGHLY and wipe dry.

DO NOT use common steel wool, scouring pads, scrapers, wire brushes, files or other steel tools to clean stainless steel. Such items will scratch the surface or leave small particles of iron imbedded in the surface, which will eventually rust and stain the surface - even appearing as if the stainless itself was rusting.

Certain chemical compounds, if used on stainless steel, can give the appearance of rust and if allowed to stand for long periods of time, can pit the surface of stainless steel. Products containing hydrochloric acid, muriatic acid or potassium hydrochloride can ruin the surface.

## **Troubleshooting - Infrared Sensors**

- I. Faucet does not function (red light does not appear when user steps in front of sensor)
  - A. No power to sensor. Make certain that power is on. Check transformer leads and connections. Repair or replace as necessary.
  - B. Willoughby 700150 IR Sensor not operating. Replace Willoughby 700150 IR Sensor.
  
- II. Faucet does not function (red light appears when user steps in front of sensor and solenoid does not click)
  - A. Debris in solenoid; disassemble, clean, and flush.
  - B. Solenoid not wired correctly; check solenoid connections.
  - C. Solenoid problem; replace solenoid.
  
- III. No water when activated (valve clicks)
  - A. Make certain that water is turned on.
  - B. Valve clogged. Clean or replace filter.
  
- IV. Very low flow or slow dribble
  - A. Check supply stop(s); open if closed.
  - B. Debris in filter; remove, clean, and reinstall.
  - C. Debris in aerator or spray head; remove, clean and reinstall.
  - D. Disassemble solenoid; clean and flush.
  
- V. Continues to run (with power on and red light flashing)
  - A. Non-permanent target in range after user leaves. Remove non-permanent target. If this target is a new permanent target (i.e., a new wall or partition), turn off 24 volt power for fifteen (15) seconds. Turn power back on and let the sensor complete start-up mode.
  - B. Sensor failure; replace sensor.
  
- VI. Continues to run (even with power disconnected)
  - A. Solenoid valve installed backwards.
  - B. Debris in solenoid, won't close properly; remove operator and clean. Reassemble in the same manner.

## **Troubleshooting - Electronic Valves**

The two most common reasons an electronic valve does not operate properly are: (1) lack of power or (2) lack of water pressure. The following steps should be used as a guide in identifying the problem of a malfunctioning electronic valve.

- I. Lack of power
  - A. Verify that the 110V GFCI outlet has power
  - B. Check all connections to ensure they have been made correctly:
    1. Cable connecting the valve coil and the timer or IR sensor
    2. Cable connecting the timer and the pushbutton (Piezo only)
    3. Cable connecting the timing device and the 24VAC transformer
    4. The 24VAC transformer and the 110V GFCI outlet
  - C. If the valve is wired correctly, the solenoid will make a “click” sound indicating that the valve has been actuated. The electronic valve is actuated by either the piezo pushbutton or the triggering of the infrared sensor (see the Start-Up Instructions for Infrared Sensors in this manual).
  
- II. Lack of water pressure
  - A. Check the supply to the rough-ins
  - B. Make sure the screwdriver stops are in the open position
  - C. Water pressure needs to be above 20psi to operate the valve
    1. If the water supply pressure is above 20psi but not exiting the valve:
      - a. Clean any debris from the screen on the inlet side of the solenoid valve body
      - b. Remove the screws on the valve body and clean any debris from the diaphragm

After all of the above steps have been followed, if there is still no water coming out of the spray head, there may be a damaged or defective part (see installation notice in the front of this manual).

---

## **Troubleshooting - Pneumatic Valves**

- I. Valve will not open or deliver water
  - A. Check the plastic tubing that runs from the pushbutton actuator to the pneumatic valve for air leaks.
  - B. Make sure the checkstop on the supply to the valve is fully open. Do not partially close the checkstop for any reason as it is not a throttling valve. The checkstop should be fully open (normal operation) or fully closed (when servicing the valve).
  - C. Close checkstop and then inspect the strainer in the supply line (installed after the checkstop) to make sure the strainer is not blocked or partially blocked, prohibiting water flow.
  
- II. Valve will not shut off
  - A. Separate valve motor from casting by removing the four (4) #8 screws.
  - B. Inspect the water diaphragm assembly to see if bypass hole in diaphragm is blocked. Remove any debris by blowing on diaphragm or using force of air. Do not use any tool (such as straight pin) to remove any debris. Enlarging the hole will shorten or make for erratic cycling.
  - C. Check the metering screw on the timer assembly to make sure the adjustment screw is not closed too tightly. To reset, back out adjustment screw (counterclockwise) about 1-1/2" turns, and adjust for the desired cycle.
  
- III. Valve continues to trickle or partially deliver water after cycle is over
  - A. Inspect seating area on valve base to make sure no debris, pitting, or scoring is present.
  - B. Clean seat or replace seat as necessary.
  - C. Inspect seating area of diaphragm for debris, clean as necessary. If debris has caused permanent indentations in the rubber, it may have to be replaced.

After all of the above steps have been followed, if there is still no water coming out of the spray head, there may be a damaged or defective part (see installation notice in the front of this manual).

***(Page intentionally left blank)***



**DRAWING: General Dimensions  
 and Rough-in Detail**

	<b>Willoughby Industries Inc.</b> Indianapolis, Indiana		Title or Part Description: <b>36" DEEP BOWL WASHFOUNTAIN MODEL WAF-3606 6 STATION</b>				Drawing #: <b>810922</b>	
	Unless otherwise specified dimensions are +/- 1/4"		Material: N/A	Drawn By: JBU	Scale: NONE	Date: 01/29/02	Qty: N/A	Revision #: B
		Job Name: N/A	Job Number: N/A		Job Number: N/A		03/19/02	Approved By:
								Sheet: 1 of 1

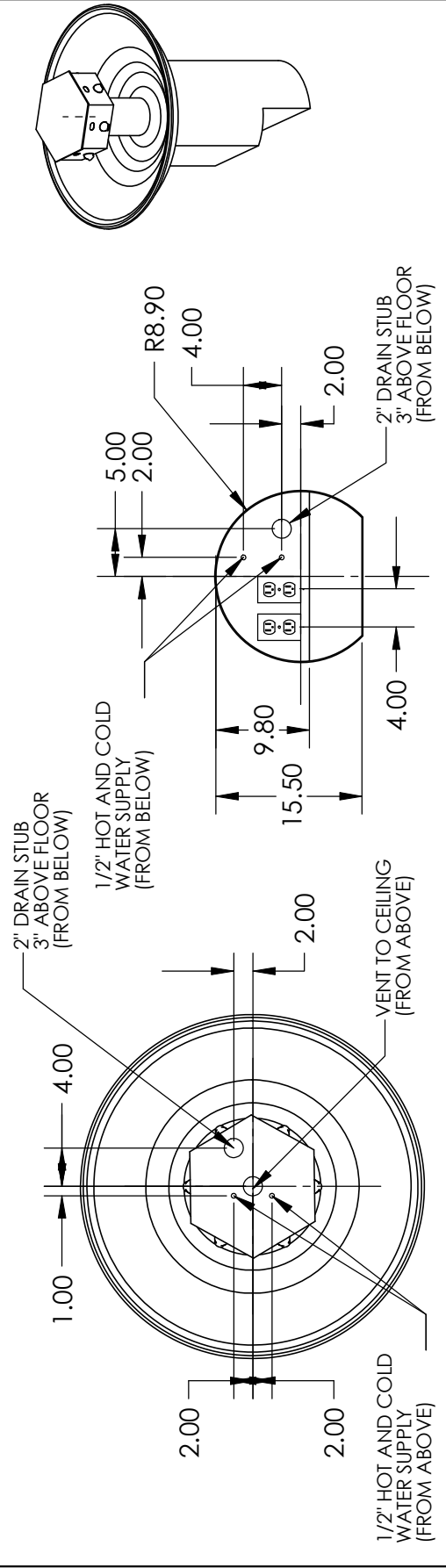

ROUGH-IN  
WITH SUPPLIES FROM BELOW

ROUGH-IN  
WITH SUPPLIES FROM ABOVE

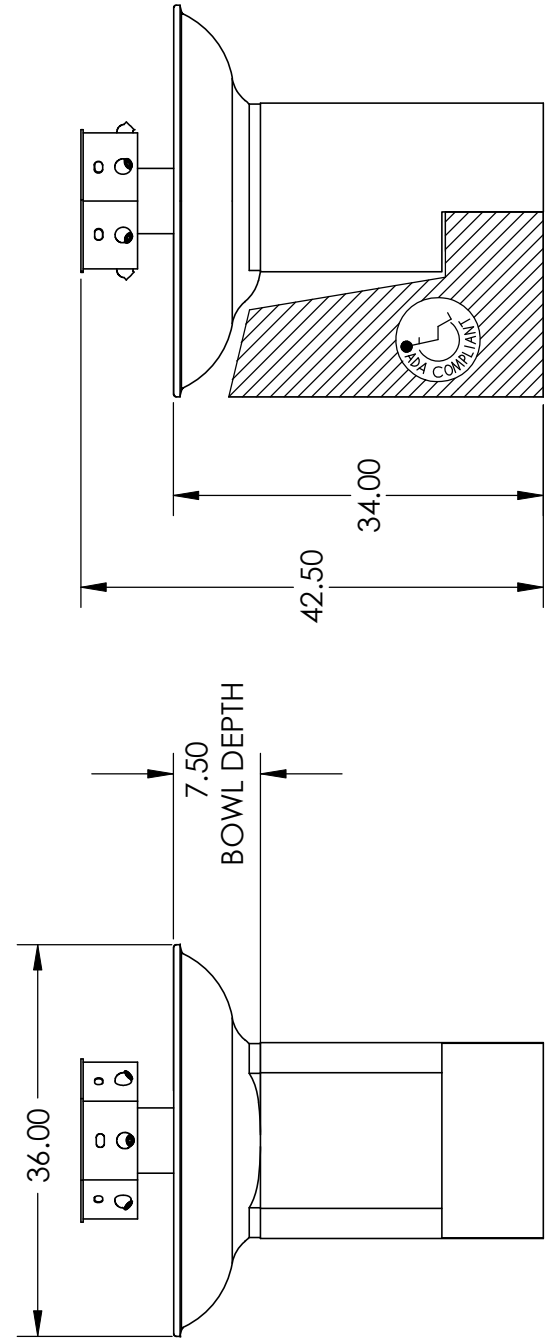

**DRAWING: Electronic Valve Detail**

 <p><b>WILLOUGHBY</b></p>	<p><b>Willoughby Industries Inc.</b> Indianapolis, Indiana</p>		<p>Title or Part Description: <b>VAVLE ASSY, WASHFOUNT 6-STATION (EL)</b></p>		<p>Drawing #: <b>803105-6EW</b></p>	
	<p>Tolerances Except as Noted</p>	<p>2 Places +/- .03 3 Places +/- .015 Fractions +/- 1/32" Angle +/- 1°</p>	<p>Material: Job Name: N/A</p>	<p>Drawn By: TRB Scale: 1:8 Part Number:</p>	<p>Date: 11/7/11 Qty: N/A</p>	<p>Revision #: <b>B</b></p>

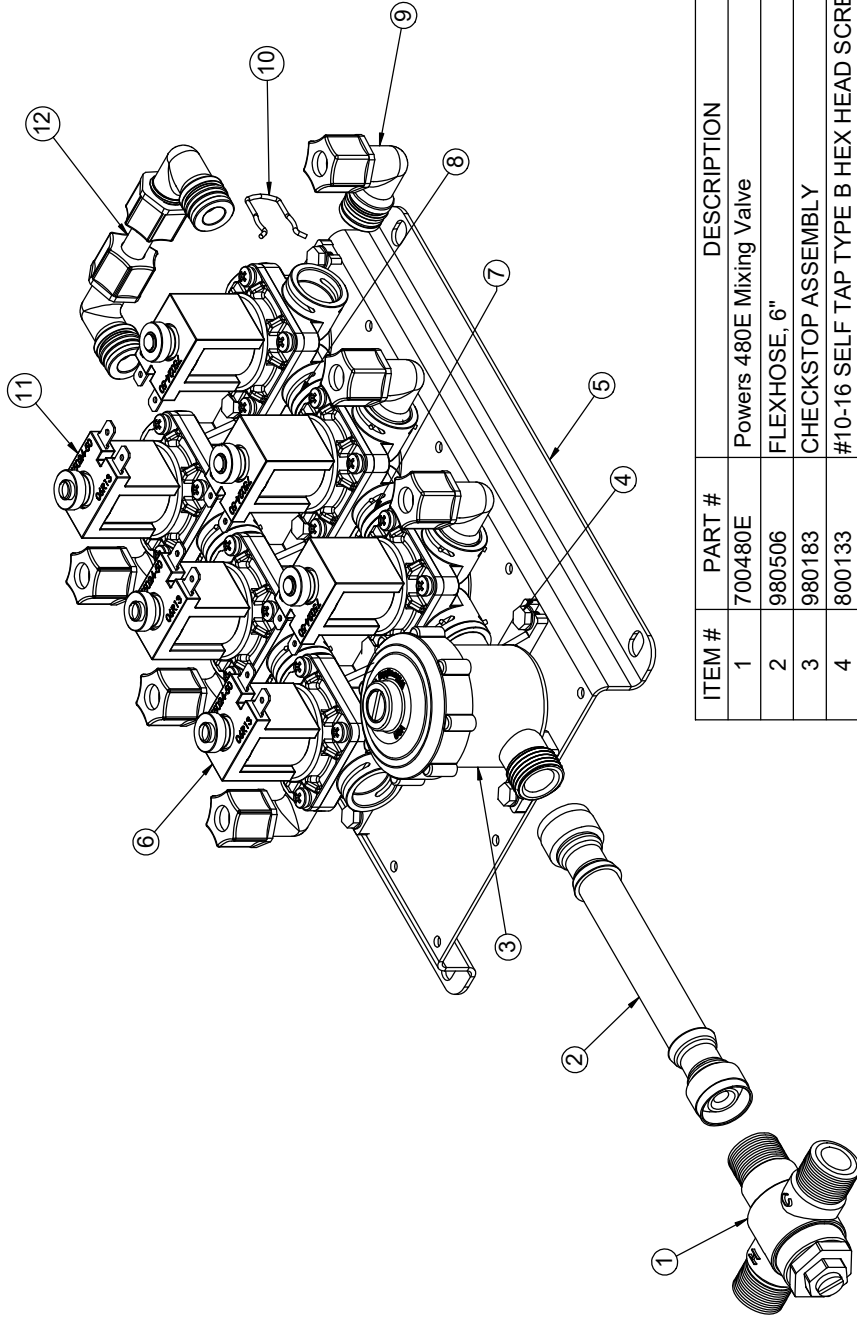

ITEM #	PART #	DESCRIPTION	QTY.
1	700480E	Powers 480E Mixing Valve	1
2	980506	FLEXHOSE, 6"	1
3	980183	CHECKSTOP ASSEMBLY	1
4	800133	#10-16 SELF TAP TYPE B HEX HEAD SCREW	14
5	9805023	PM2-MA3 Valve Bracket - Plastic	1
6	980408PR	E1L VALVE ASSEMBLY, RIGHT - PLUGGED PORT	1
7	980164	O-RING, #015	8
8	980197	PLASTIC VALVE COUPLING	4
9	980600A	VALVE FITTING ASSEMBLY, 3/8" ELBOW	8
10	980140	SPRING CLIP	17
11	980408	E1L VALVE ASSEMBLY	5
12	600523	FLEXIBLE TUBING 3/8" (10mm) OD (2")	1
13	980520	FLEXHOSE, 20" (NOT SHOWN)	2

NOTE:  
PART #13 - FLEXHOSE, 20" NOT SHOWN

**DRAWING: Electronic Valve Detail**

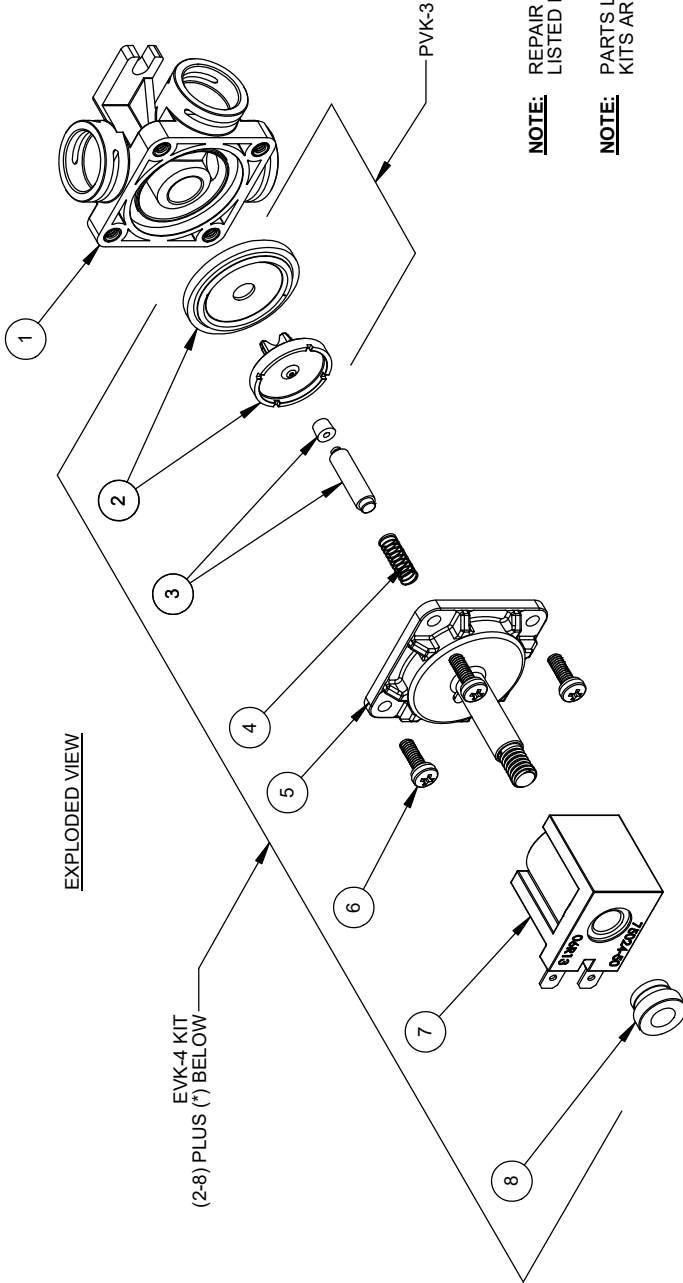

**NOTE:** REPAIR KIT ORDERING #'S ARE LISTED IN THE EXPLODED VIEW.  
**NOTE:** PARTS LISTED IN THE PVK REPAIR KITS ARE NOT SOLD INDIVIDUALLY

\* EVK-4 KIT INCLUDES 380897 VALVE SEAT W/ O-RING (NOT SHOWN)

ITEM #	PART #	DESCRIPTION	QTY.
1	980420	SINGLE TEMP BASE w/INSERTS (ALL PORTS OPEN)	1
2	980305	WATER SIDE DIAPHRAGM/ADAPTOR ASSY.	1
3	980565	ARMATURE BUMPER ASSEMBLY, EL VALVE	1
4	980533	SPRING, 5/8 24V VALVE	1
5	980530	ARMATURE CAP, 24V VALVE	1
6	980170A	#8-32 x 1/2 " SCREW	4
7	980532	COIL, 24V DC	1
8	980534	NYLON NUT, 5/16-18	1

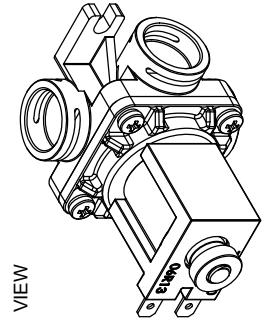

ASSEMBLED VIEW

		<b>Willoughby Industries Inc.</b> Indianapolis, Indiana	
TOLERANCES EXP'AS NOTED	2 DEC 2015 3 FCS 2015	SIZE: A	MATL:
ANGLE: 2°	SCALE: 1:2	REF:	
TITLE / DESC: E1L VALVE ASSEMBLY (ALL PORTS OPEN)		PART #: 980408	
REVISION ORG: TRB 09/23/09 STANDARD		REV: TRB 03/15/11 SHEET: 1 OF 1	

**DRAWING: Pneumatic Valve Detail**

 <p><b>WILLOUGHBY</b></p>	<p><b>Willoughby Industries Inc.</b>                  Indianapolis, Indiana</p>	<p>Title or Part Description:  <b>VAVLE ASSY, WASHFOUNT 6-STATION (PNEUMATIC)</b></p>		<p>Drawing #:  <b>803105-6PW</b></p>
	<p>Tolerances                  Except as                  Noted</p>	<p>2 Places +/- .03                  3 Places +/- .015                  Fractions +/- 1/32"                  Angle +/- 1°</p>	<p>Material:                  Job Name: N/A</p>	<p>Drawn By: TRB                  Scale: 1:8                  Part Number:</p>

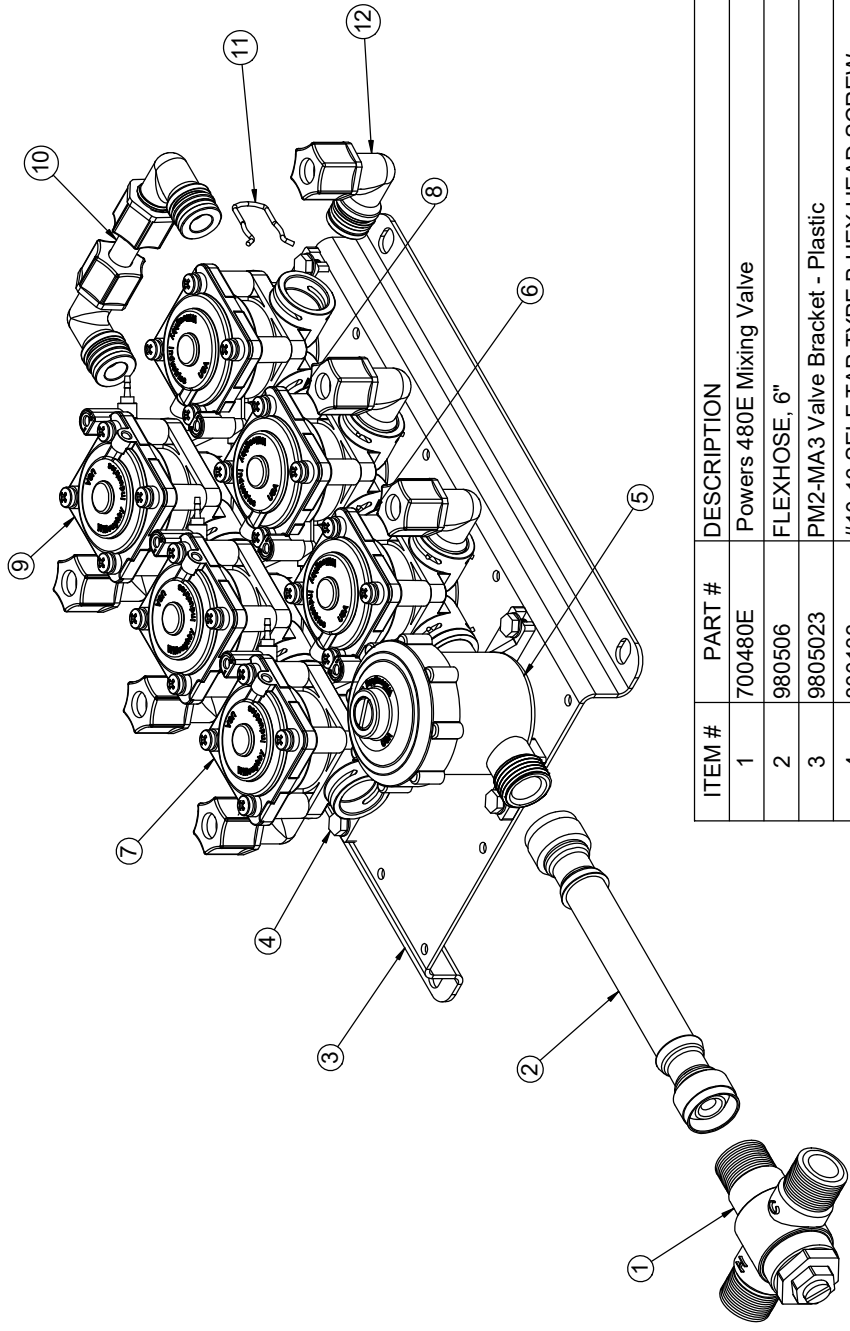

ITEM #	PART #	DESCRIPTION	QTY.
1	700480E	Powers 480E Mixing Valve	1
2	980506	FLEXHOSE, 6"	1
3	9805023	PM2-MA3 Valve Bracket - Plastic	1
4	800133	#10-16 SELF TAP TYPE B HEX HEAD SCREW	14
5	980183	CHECKSTOP ASSEMBLY	1
6	980197	PLASTIC VALVE COUPLING	4
7	980406PR	PNEUMATIC VALVE ASSEMBLY, RIGHT - PLUGGED PORT	1
8	980164	O-RING, #015	8
9	980406R	PNEUMATIC VALVE ASSEMBLY	5
10	600523	FLEXIBLE TUBING 3/8" (10mm) OD (2")	1
11	980140	SPRING CLIP	17
12	980600A	VALVE FITTING ASSEMBLY, 3/8" ELBOW	8
13	980520	FLEXHOSE, 20" (NOT SHOWN)	2

NOTE:  
 PART #13 - FLEXHOSE, 20" NOT SHOWN

**DRAWING: Pneumatic Valve Detail**

ITEM #	PART #	DESCRIPTION	QTY.
1	980420	SINGLE TEMP BASE w/INSERTS (ALL PORTS OPEN)	1
2	980305	WATER SIDE DIAPHRAGM/ADAPTOR ASSY.	1
3	980310	WATER SIDE DISK ASSEMBLY	1
4	980136	SPRING, WATER SIDE DIAPHRAGM	1
5	980126	BARRIER CUP	1
6	980127	O-RING M1.5x32 BUNA-70	1
7	980410	METERING VALVE BODY ASSEMBLY	1
8	980135	SPRING, AIR SIDE MAGNET	1
9	980405	METERING VALVE MAGNET/CUP ASSEMBLY	1
10	980130	DIAPHRAGM, AIR SIDE, PNEUMATIC METERING VALVE	1
11	980134	AIR SIDE SPRING	1
12	380801M	AIR SIDE TOP COVER	1
13	980001A	#8-32 x 1 1/4" SCREW	4

**NOTE:** PARTS LISTED IN THE PVK REPAIR KITS ARE NOT SOLD INDIVIDUALLY

**NOTE:** REPAIR KIT ORDERING #'S ARE LISTED IN THE EXPLODED VIEW.

**NOTE:** PVK-1M, PVK-2, & PVK-3 PARTS ARE AVAILABLE IN KIT FORM ONLY.

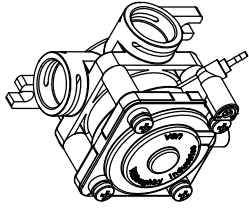

ASSEMBLED VIEW

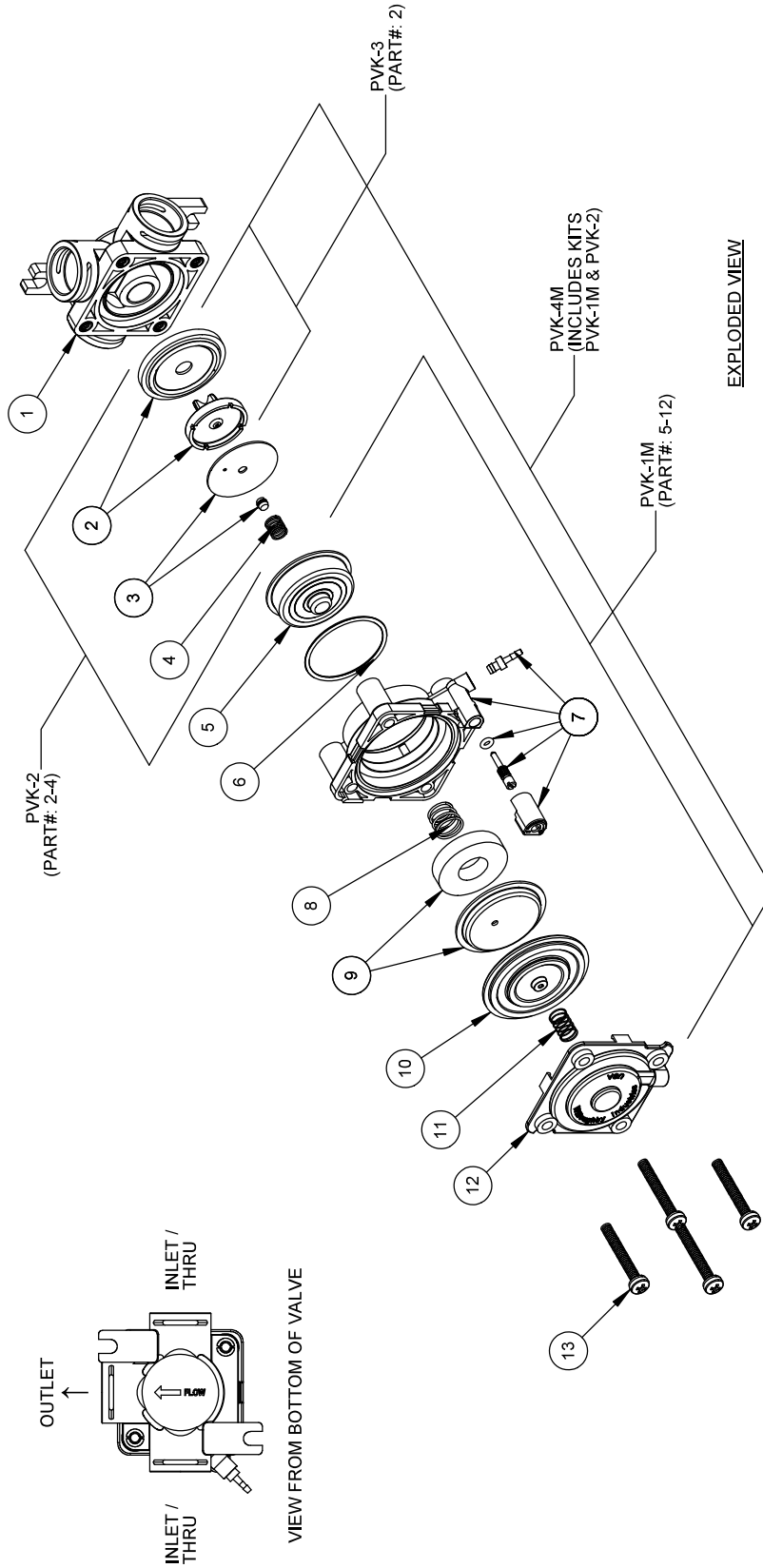

EXPLODED VIEW

	<b>Willoughby Industries Inc.</b> Indianapolis, Indiana	TITLE (DESC): <b>PNEUMATIC METERING VALVE ASSEMBLY - (RIGHT)</b>	PART #: <b>980406R</b>
	3 PLS: #003 SIZE: A MATL:	REVIEW (DESC): TRB 10/18/12 STANDARD REV: MW 8/31/16 SHEET: 1 OF 1	TOLERANCES EXCEPT AS NOTED SCALE: 1:2.5 REF:

**DRAWING: Pushbutton Detail**

**PIEZO HEAD KIT DETAIL**

✓	WIRE TERMINATOR	INV. #
	BARE STRIPPED WIRE	701179
	1/4" FEMALE SPADE CONNECTION	701179-C

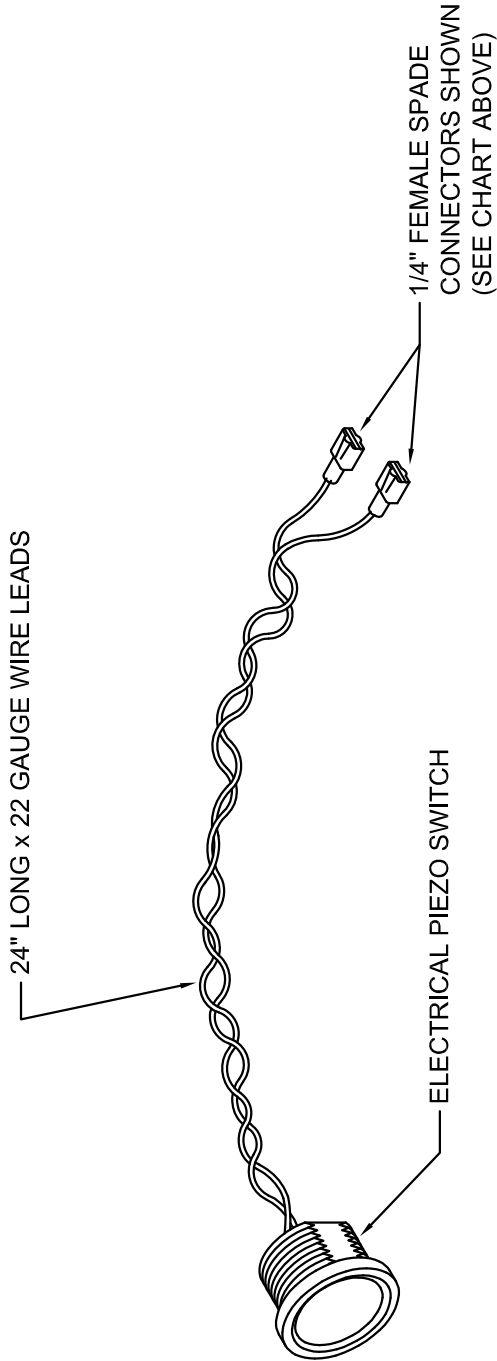

**PIEZO SWITCH SPECIFICATIONS**

**PIEZO SWITCH HOUSING:**

- MATERIAL: STAINLESS STEEL
- MOUNTING GEOMETRY: DOUBLE 'D' HOUSING
- SUPPLIED WITH NUT FOR MOUNTING
- 2 FT. LEADS INTEGRAL TO SWITCH (EXTENSION CABLES CAN BE SPECIAL ORDERED)
- EXTERNAL HOUSING OF SWITCH ELECTRICALLY ISOLATED FROM CIRCUITRY OF SWITCH

**OPERATIONAL RATINGS:**

- ACTUATION FORCE: LESS THAN 5 LBS.
- MAXIMUM VOLTAGE: 36 VOLTS AC/DC
- MAXIMUM AMPERAGE: 100 MA

**DRAWING: Push Button Detail**

**NOTE: PARTS 2 AND 3 MUST BE PURCHASED TOGETHER**

ITEM #	PART #	DESCRIPTION	QTY.
1	600307RK	REPAIR KIT FOR DIAPHRAGM PUSHBUTTON PUMP	1
2	380840	FITTING, HOSE BARB, PUSH-IN, 1/16" (BRASS)	1
3	380506MA	BODY, PUSH BUTTON DIAPHRAGM PUMP, MOLDED	1
4	600201	DIAPHRAGM, PNEUMATIC PUMP	1
5	380504MA	CAP, DIAPHRAGM PUMP, MOLDED	1
6	600057	PUSHBUTTON, DIAPHRAGM PUMP	1
7	380124	SLEEVE, DIAPHRAGM PUMP PUSHBUTTON	1

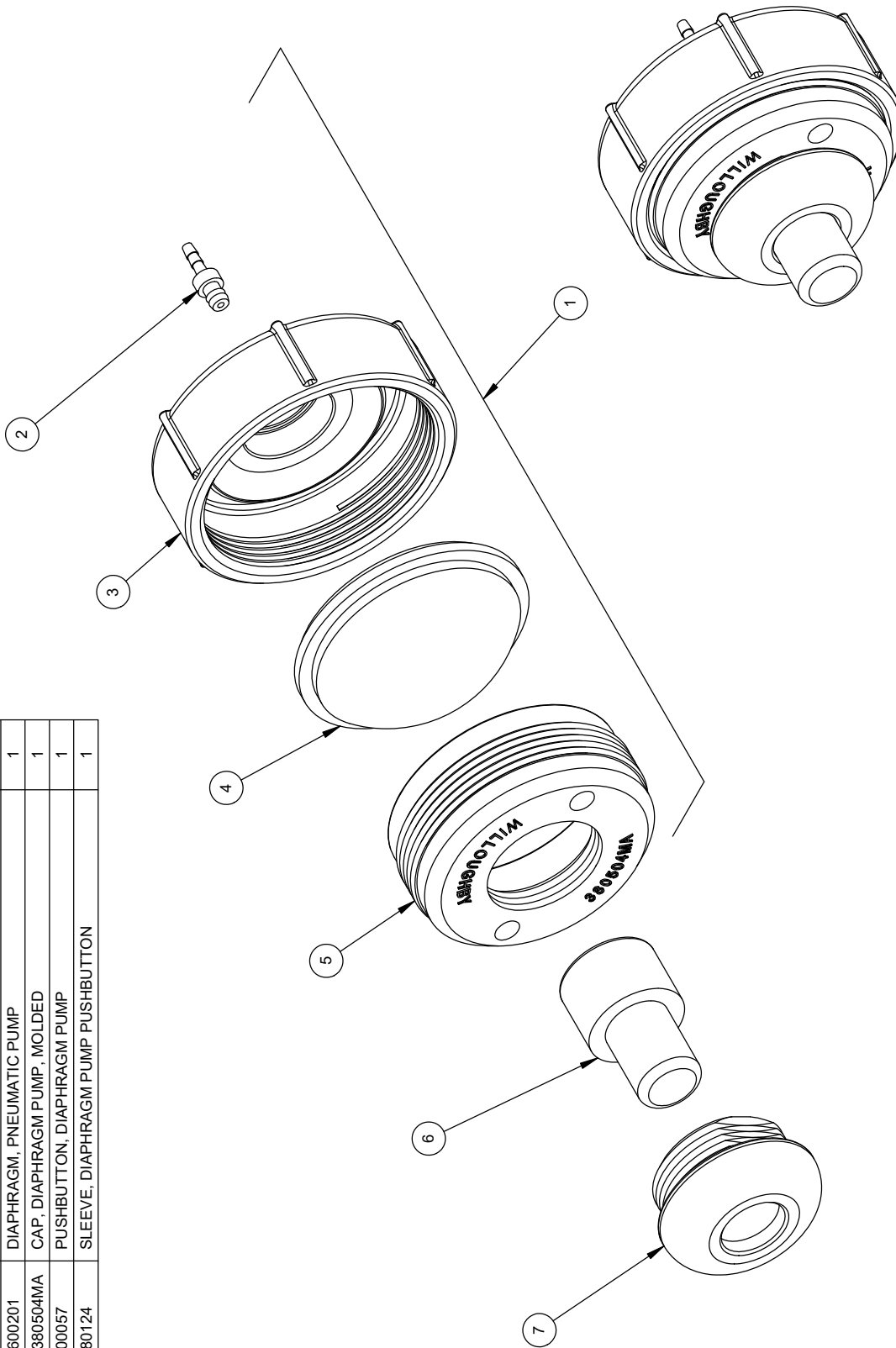

 WILLOUGHBY	Willoughby Industries Inc. Indianapolis, Indiana	TITLE / DESC: (PPB) PNEUMATIC PUSHBUTTON	PART #: 600307
	TOLERANCES: DECIMALS: .005 FRACTIONS: 1/32 AS NOTED SCALE: 1:1	MATL: A AS NOTED. SEE BOM REF.	REVISION: JBU 3/14/00 STANDARD REV: MW 10/26/16 A

**DRAWING: Spray Head Detail**

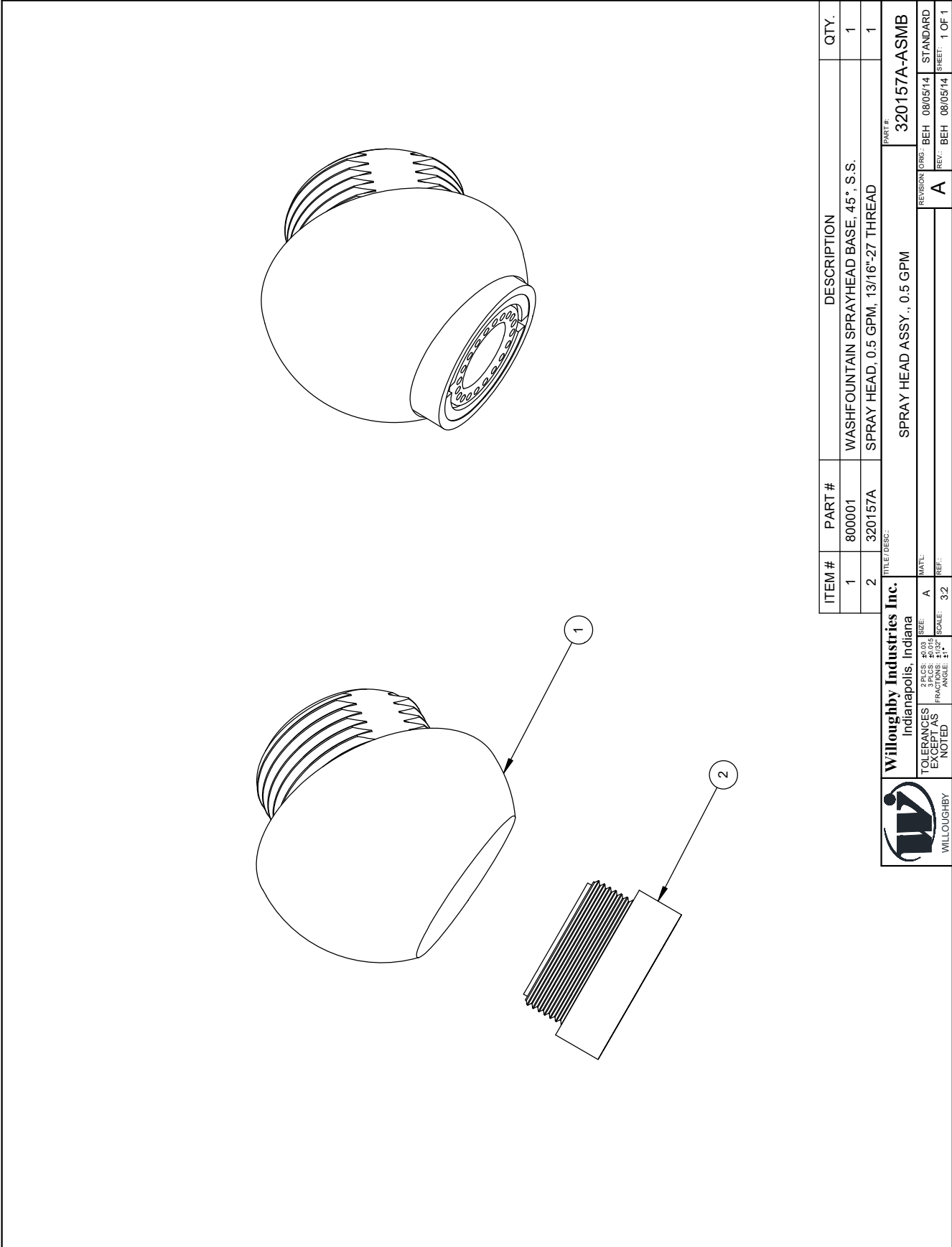

ITEM #	PART #	DESCRIPTION	QTY.
1	800001	WASHFOUNTAIN SPRAYHEAD BASE, 45° S.S.	1
2	320157A	SPRAY HEAD, 0.5 GPM, 13/16"-27 THREAD	1

**Willoughby Industries Inc.**  
Indianapolis, Indiana

2 PLS. ±0.03  
3 PLS. ±0.015  
FRONT VIEW  
ANGLE: 3°

TOLERANCES EXCEPT AS NOTED

SCALE: 3/2

MATL: A  
REV: 08/05/14

REV: BEH 08/05/14

STANDARD SHEET: 1 OF 1

PART #: 320157A-ASMIB

TITLE/DESC: SPRAY HEAD ASSY., 0.5 GPM

WILLOUGHBY



		<b>GEN II SOAP PUMP</b>				Drawing #: <b>800270C</b>	
		Title or Part Description:		Date: 12/01/03		Revision #: <b>C</b>	
Willoughby Industries Inc. Indianapolis, Indiana		Material: SEE DETAILS		Drawn By: JR		City: N/A	
Tolerances Except as Noted 2 Places +/- .01 3 Places +/- .005 Fractions +/- 1/32" Angle +/- .3°		Job Name: N/A		Scale: NONE		Job Number: N/A	
				Date: 12/21/12		STANDARD DWG. Sheet: 1 of 1	

ITEM NO.	PART #	DESCRIPTION	QTY.
1	600768	O-RING (#019)	2
2	800290	SOAP PUMP BASE, GEN II	1
3	800294	RUBBER FLAPPER VALVE, SOAP PUMP	1
4	800295	SOAP PUMP SPRING SEAT	1
5	800298	SOAP PUMP PISTON SPRING	1
6	800299	O-RING (2-012) PISTON	1
7	N/A	SOAP PUMP PISTON, GEN II (#800291)	1
8	N/A	SOAP PUMP BODY, GEN II (#800292)	1
9	N/A	BUMPER-SOAP PUMP CHECK VALVE (#800289)	1
10	N/A	SPRING FOR CHECKSTOP (#600234)	1
11	N/A	SOAP PUMP PLUNGER, GEN II (#800293)	1
12	800128	SCREW #8-32 x 3/16" SCKT SET S/S	1
13	800103	REBUILD KIT (ITEMS 3,4,5,6 & (2) ITEM #1'S	1

NO SERVICE PARTS AVAILABLE

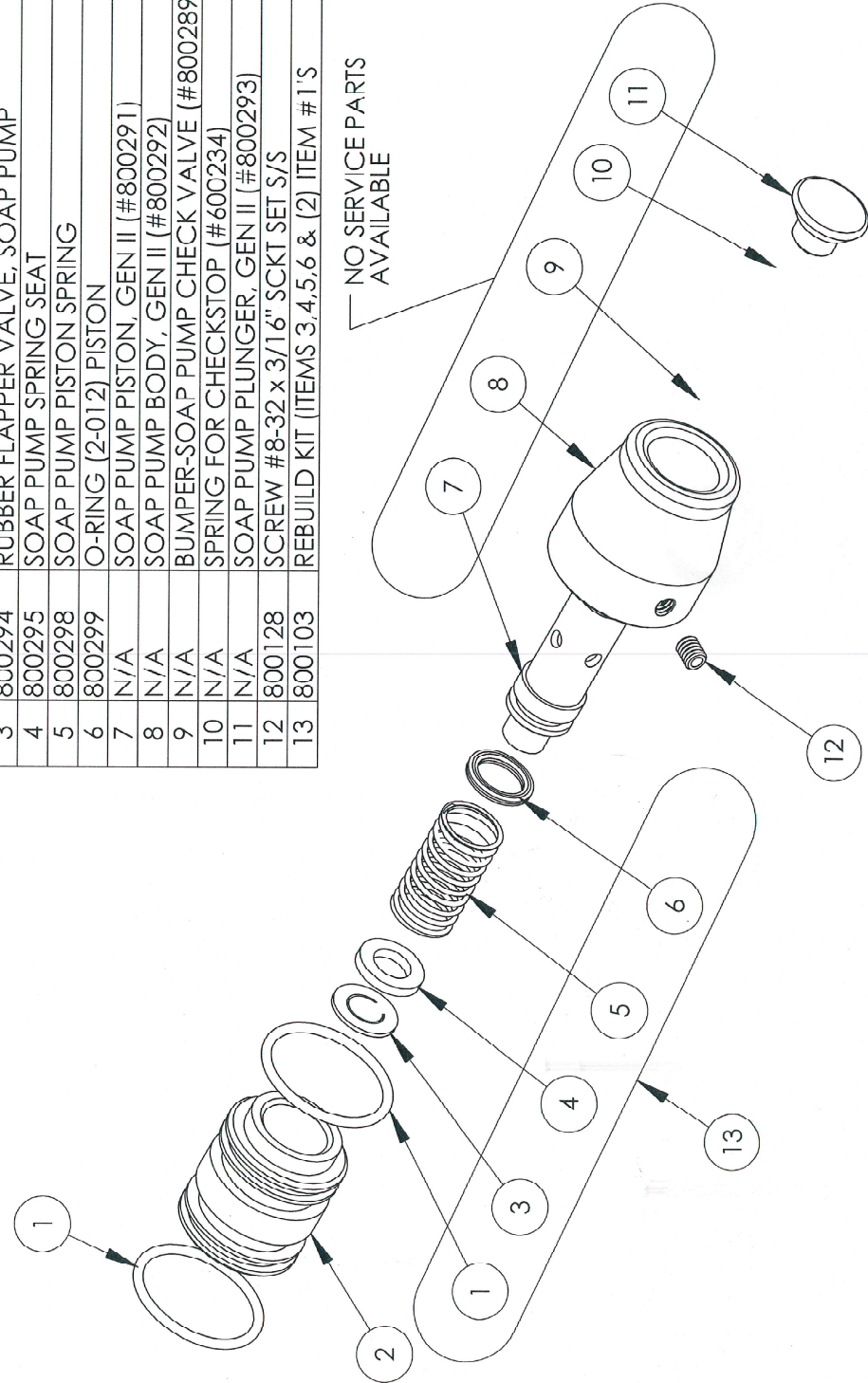
## **Warranty**

Solid surface products are a homogenous blend of resins, mineral filler and colorant manufactured for panels, molded and/or shaped products and components. Solid surface products provide a luxurious appearance with the durability of stain proof, impact resistant, burn resistant material with the ease of maintenance and cleaning.

Willoughby Industries, Inc. warrants to commercial and institutional purchasers only that each unit will be free from defects in workmanship and materials under normal use and service upon the following terms and conditions. The period during which components are warranted is as follows:

1. Solid surface components are warranted for 2 years from date of shipment.
2. All other components warranted for 1 year from date of shipment.

This warranty does not cover installation or any other labor charges and does not apply to any components damaged by accident, abuse, improper installation or improper maintenance. This warranty does not cover any installation that did not comply with national, state and local building, plumbing or electrical codes. The warranty is limited to replacing or repairing at manufacturer's option, transportation charges prepaid by the purchaser, any component or part which upon our inspection shall be deemed as defective within the limitations of this warranty. The replacement or repair of defective units as stated in this warranty shall constitute the sole remedy of the purchaser and the sole liability of Willoughby Industries, Inc. Willoughby Industries, Inc. shall not otherwise be liable under any indirect damages caused by defects in the repair or replacement thereof.

This warranty only extends to commercial and industrial purchasers and does not extend to any others, including consumer customers of commercial institutional purchasers. This warranty is in lieu of all other warranties, expressed or implied, including implied warranty of merchantability or fitness for a particular purpose or otherwise.